

Mixed-Class & Mixed-Topology Amplifiers

If only we could save our cake and eat it at the same time. The aim of a mixed class amplifier is to provide the high quality sound of Class-A operation with the greater efficiency and power output of Class-B operation. An additional aim might be to further the listener's ability to tune the amplifier's sound by means of a single potentiometer...but let's not get too far ahead of ourselves.

At first, all new amplifier topologies are hard to understand. Imagine when all amplifiers were single-ended how difficult it must have been to explain push-pull operation. What is "phase" and why does it need to be split? If the output transformer isn't partially magnetized and doesn't have an air gap, how can it work? These and other questions would require careful answering, as push-pull operation also brought the possibility and the complication of Class-AB and Class-B operation of the output tubes, which were not possible in the strictly Class-A world of single-ended operation. More questions and more answers would be needed.

Well, now I am asking you to imagine a mixed-class amplifier, one that is at once both Class-A and Class-B. No, this is not the same as the marketing of OTL Class-AB amplifier as Class-A nor is this along the lines of those pseudo-Class-A amplifiers from the 70s that never let the output devices cutoff even though they made no real contribution to the amplifier's output. (Class-A operation is only valuable when both devices equal work into a load; when one device gives up its grip, it may as well not be in the circuit.)

In other words, like good cop and bad cop, good-but-weak amplifier is partnered with bad-but-powerful amplifier. (A better analogy might be the teaming of Hercules and Iolaus.) If this arrangement sounds something like the Quad current dumping amplifier, it should, as the principles behind both amplifiers are roughly the same. In Quad's design, a small Class-A amplifier was assisted by a Class-B amplifier.

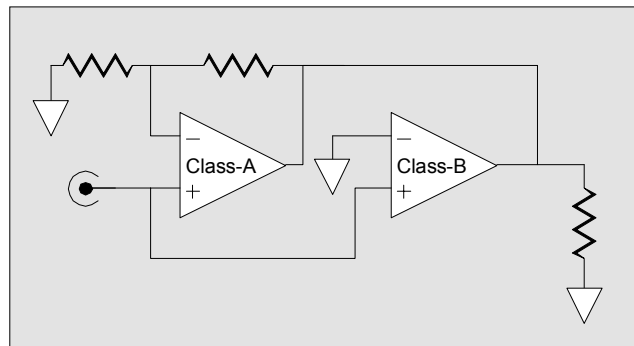

Just as push-pull operation doubled the single-ended solo output tube, mixed class operation doubles push-pull's double output tubes; thus at least four output tubes are needed. One pair runs in Class-A push-pull and the second pair runs in Class-AB or Class-B (or even Class-C) push-pull. Thus, the first pair are always conducting, while the second pair can be completely turned off (or run at a much lower current) at idle.

As the signal level increases, the second pair is activated, unburdening the first pair and greatly increasing the output power. In fact, we can just as easily mix Class-AB with Class-B or Class-C, either mix would give even greater power output.

In fact, we could easily create a three-way mix of operating classes, say Class-A, Class-AB, and Class-B, or Class-AB, Class-B, and Class-C. Of course, at least six output tubes would be needed. In all the mixes, the goal would be the same: to create a simple, seamless sounding push-pull amplifier that uses only a single input and phase splitting (and driver) stage per amplifier. This goal can be met with an near infinite mix of output tube types and bias points. One example is using a pair of EL34s for the Class-A grouping and KT88s for the Class-B pairing. Another example might be using a pair of 300Bs for the Class-AB grouping and 211s for the Class-C pairing.

How to proceed?

Two separate amplifiers on two separate chassis with two separate power supplies could be used; but what a hassle. Using one chassis with one power supply and one input stage is preferable.

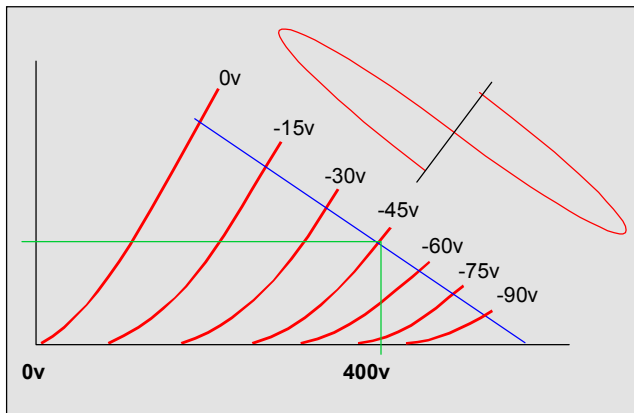

Class-A bias point and grid swing

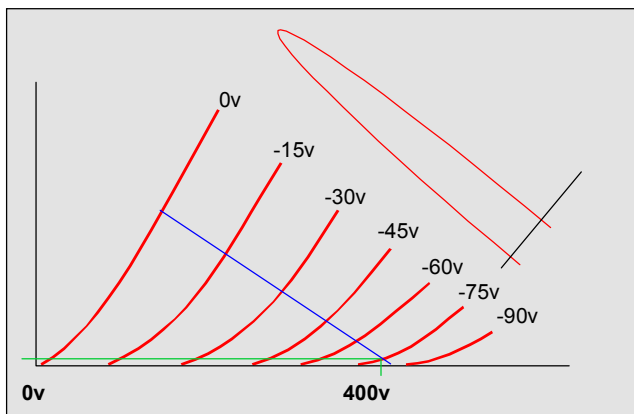

Class-B bias point and grid swing

Given the same output tubes, Class-A and Class-B push-pull amplifiers require different drive voltage swings, with Class-B needing more than Class-A. In fact, the ratio is just about 2 to 1. In the Class-A amplifier, the output tubes are biased at the midpoint between drawing grid current and being completely turned off. In the Class-B amplifier, on the other hand, the output tubes are biased at the endpoint just above of being completely turned off. Because a Class-B push-pull amplifier's output tubes need twice the input grid swing to bring the grid to the onset of conduction as the tubes would in Class-A operation, a better ordering might be: EL34s for the for the Class-A grouping and EL84s for the Class-B pairing (or 300Bs for the for the Class-A grouping and 6550s for the Class-B pairing). For example, the EL34 would need to see about 30 volts of peak grid voltage swing in Class-A and the EL84 would need to see about 30 volts of peak grid voltage swing in Class-B.

Alternatively, the Class-A pairing and the Class-B pairing could share the same type of tube. Two approaches immediately come to mind: give the output pairings dissimilar drive voltages or halve the Class-A pairing's transconductance. The first approach requires as little as using two plate resistors in series. In the circuit shown below, we see differentially arranged triodes with series plate resistors. The bottommost set of outputs go to the Class-B pairing and the topmost outputs go to the Class-A pairing. (A further refinement might be to cross-couple outputs and inputs with small capacitors to extend the frequency response.)

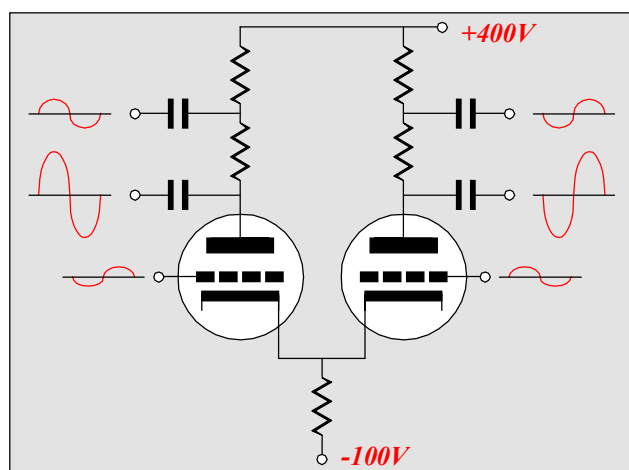

Dual outputs for Class-A & Class-B output pairs

This same multi-tapping of a split-load phase splitter is easy to construct. However, one liability stands out: the PSRR is substantially worse from the plate as from the cathode. This means that the noise that would normally be cancelled out in the push-pull output stage becomes amplified when the power supply noise presented to the output stage's grids is not equal in amplitude and in phase. Even my trick of giving this phase splitter half of the power supply noise to bring the dissimilar PSRRs into alignment fails when multi-tapped, as the midpoint between plate and B+ has 75% of the power supply noise, whereas the midpoint between cathode and ground only contains 25% of power supply noise. In other words, this phase splitter can be used, only if an extremely well filtered (or regulated) power supply is used.

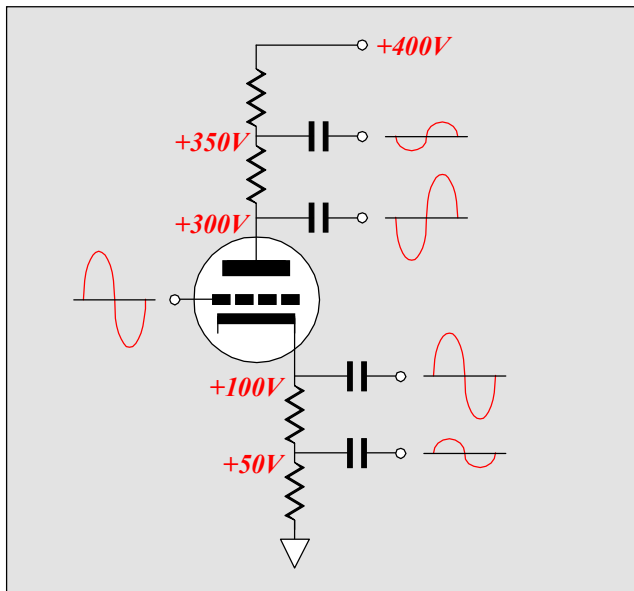

Split-load phase splitter with multi-taps

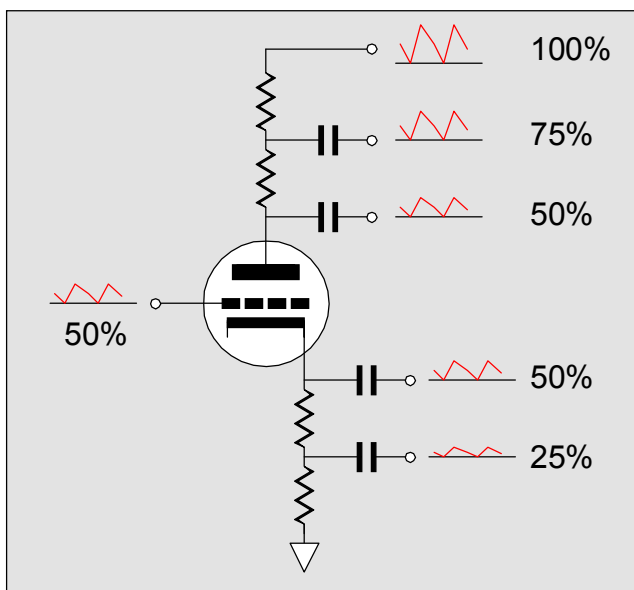

Split-load phase splitter's PSRR per tap when fed an input signal with 50% of power supply noise

The other approach is to give all output tubes the same drive signal, but halve the Class-A pairing's transconductance, which would require an effective doubling of its drive requirements. How can a triode's transconductance be decreased? Well, just placing a plate resistor in series with the triode will reduce its transconductance, as a triode is sensitive to its plate voltage, which this resistor will alter.

For example, when the plate load equals the r_p of the triode, its transconductance is halved, as G_m is equal to $\mu / (r_p + R_a)$. Adding an unbypassed resistance in series with the cathode also decreases the triode's transconductance. When the cathode sees a resistance equal to $r_p / (\mu + 1)$, the effective transconductance is halved. For a 300B, this resistance would equal 143 ohms. Notice that resistance is too low to correctly bias the 300B. Thus slight modification is required and is shown below.

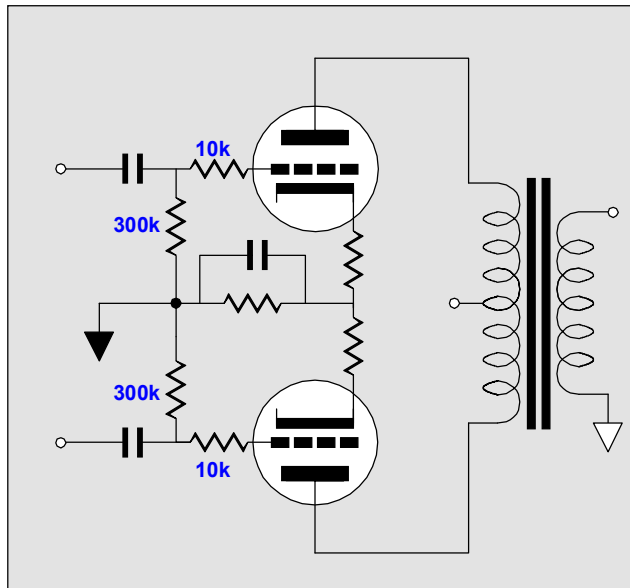

Cathode bias with transconductance halving

The problem with cathode bias is that while it works beautifully with Class-A amplifiers, whether they be single-ended or push-pull, it does not work well with Class-B amplifiers. The reason is easy to discern: in the Class-A amplifier the idle current is equal to the average current through the output tube even when the amplifier is putting out its full output. In contrast, the Class-B amplifier's idle current is but a small fraction of its conduction at full output, making its average conduction roughly half of its peak. In other words, cathode bias would result in the Class-B amplifier trying to turn its self off during heavy use, creating a good amount of distortion in the process.

The solution is to use only fixed bias for the Class-B pairing.

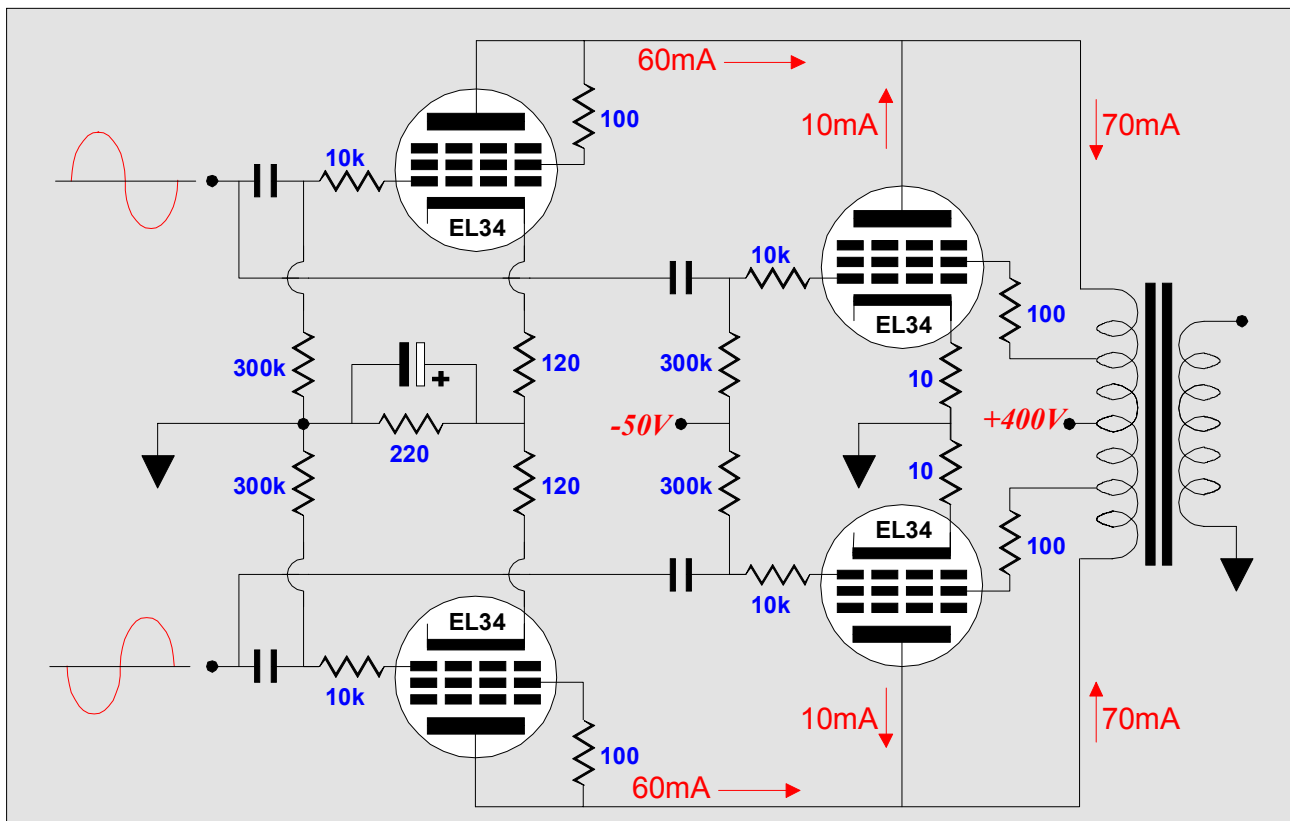

Mixed topology amplifiers

The amplifier shown above not only mixes classes of operation, but also topologies. The first pair of EL34s work as Class-A triodes, while the second pair works as Class-B ultra-linear pentodes. This amplifier would put out 60 watts of power, with 10 watts coming from the Class-A stage and 50 watts coming from the Class-B stage. The Class-B pair could just as easily be configured as pure pentodes, which might yield some benefit from its increased output impedance. In other words, having the Class-B stage produce a high output impedance allows the low-output-impedance triode pair to dominate the output, as the triode's low r_p will buck any extraneous contribution from the pentode pair by increasing or decreasing the triode's conduction in response. (As an aside, even within one output stage made up of only two output tubes, mixed mode configurations are possible. For example, in the amplifier below, we see an amplifier that is configured as an ultra-linear at low frequencies, but becomes a triode configured amplifier at high frequencies.)

Push-pull mixed mode output stage

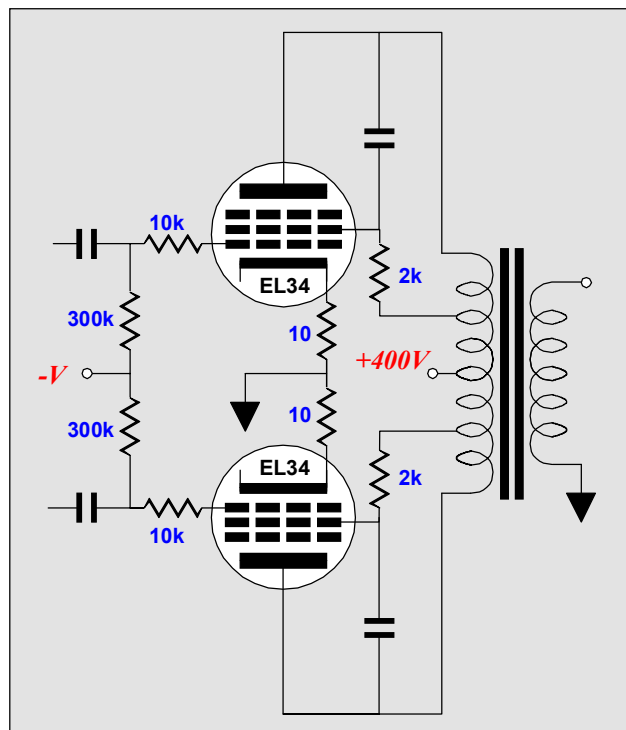

Mixed mode within one output stage

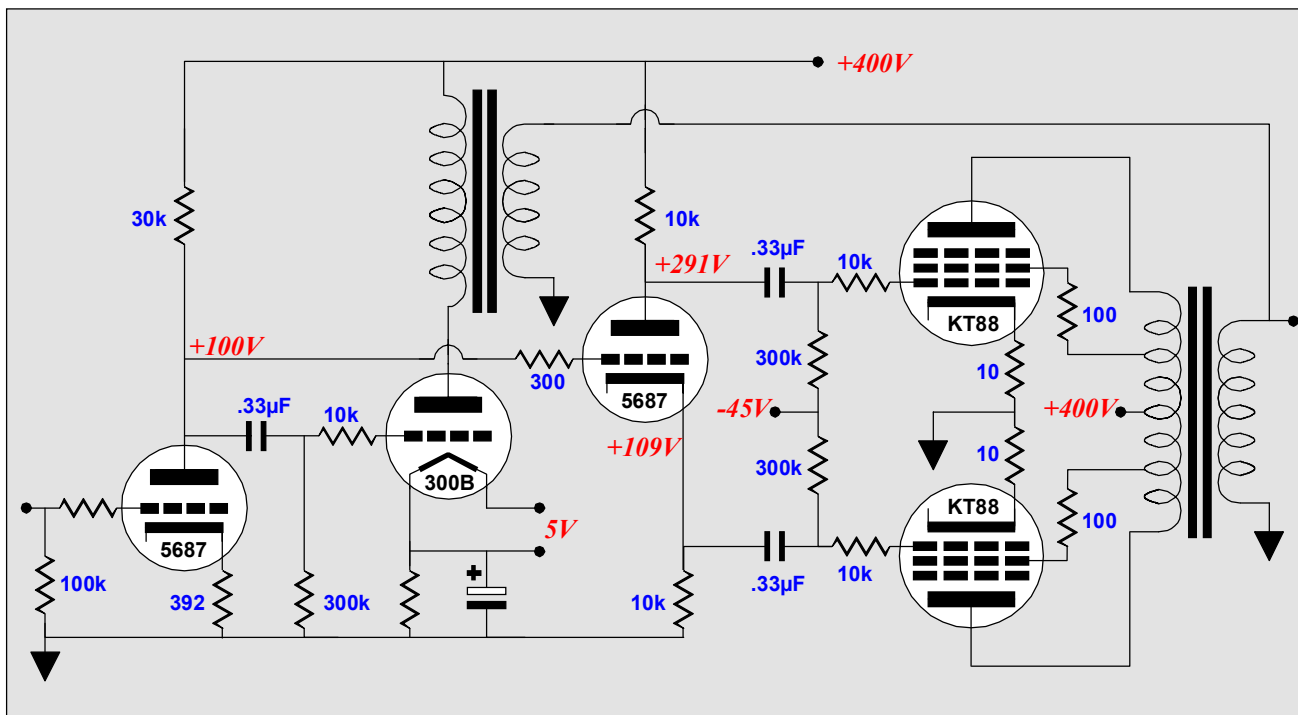

Truly mixed modes/topologies

The amplifier shown above combines Class-A and Class-B with single-ended and push-pull. Two output transformers are required, but only a single power supply and input circuit is needed. This amplifier relies on the 300B to deliver the majority of that all important first watt of power and on the 6550s to deliver the wallop missing from so many single-ended amplifiers.

I would love to see some research on the Class-A-SE/Class-AB-PP amplifier that Nelson Pass has made famous in solid-state circles. In past issues we have covered possible tube implementations of this style of amplifier. The attempts relied on using a pair of output tubes and controlling the grid signals to these tubes. An alternative approach would to add a third tube to an existing push-pull output stage. In the schematic to the right, we see a constant current source loading half the primary with a current equal to that being drawn by the bottom EL34. This balanced current ensures that the transformer will not saturate at idle. In the absence of the top EL34, the amplifier would be purely single-ended, but the top EL34 allows the to break out single-ended operation.

Class-A/Class-AB SE/PP amplifier

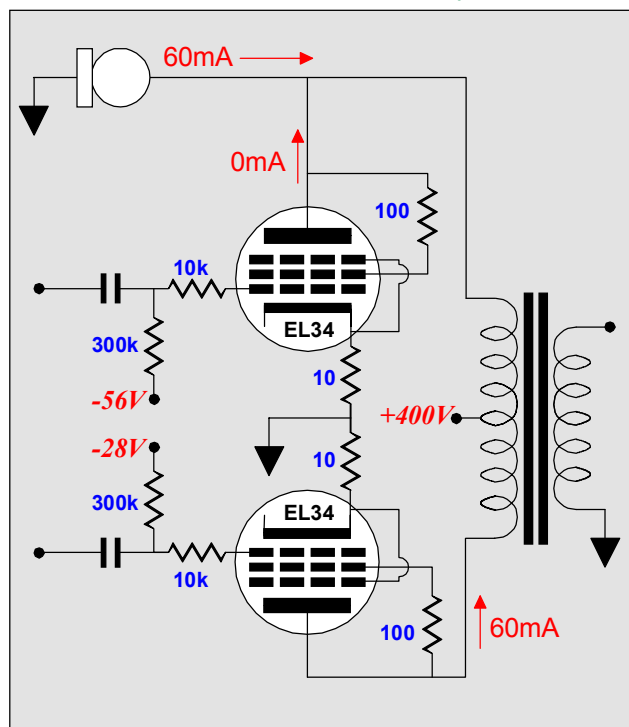

Class-A-SE/Class-AB-PP

This amplifier works as single-ended until the top EL34 turns on, creating a mixed mode push-pull amplifier, as the top EL34 works in Class-B; the bottom EL34, in Class-AB.

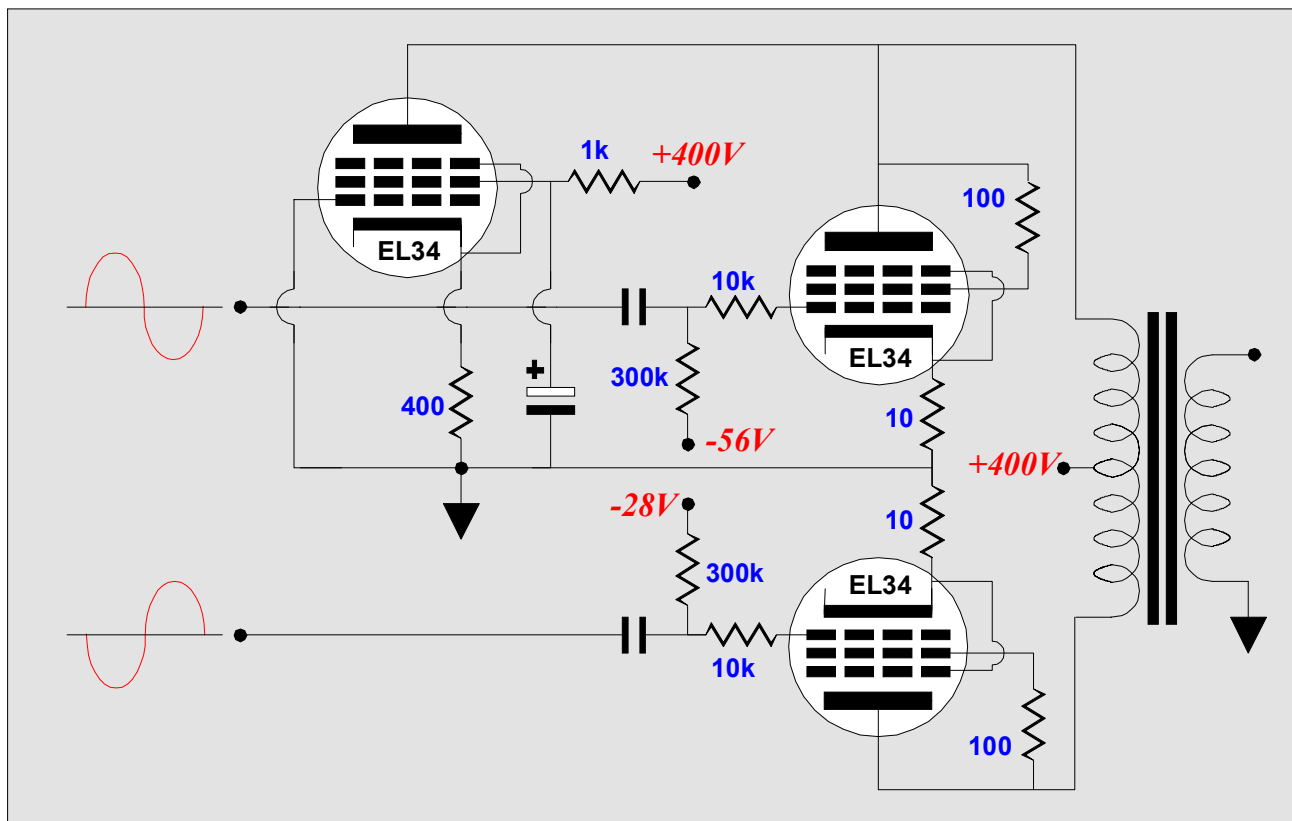

Class-A-SE/Class-AB-PP amplifier

How do we replace the constant current source with a tube? Well, since pentodes are known for their high output impedance, a pentode would be a logical place to start. In the circuit above, we see the third EL34 working as a constant current source. This third tube will draw a fairly constant current, which the bottom EL34 will have to work against at idle. As the signal level increases, the amplifier leaves single-ended operation once the top EL34 begins to conduct, but at no time does the third EL34 stop conducting. In other words, we can expect that the bottom EL34 will wear out first, followed by the third EL34. And as the top EL34 is normally turned off at idle and at low levels, it should last the longest.

Besides offering single-ended sound and push-pull wallop, this amplifier would turn many heads with its use of three output tubes. (H.G. Wells' Martians listen to such amplifiers.) The balanced idle current through the output transformer means that we do not need an airgapped output transformer, which allows experimentation on old Dynaco gear.

(A Stereo-70 would work nicely as a mono-block amplifier with the empty octal socket holding a 6SL7 or an octal dissimilar-triode tube, such as the 6DN7 or 6EM7; with the old circuit board replaced by a new board that hold only support components; and with the two output transformers wired in parallel.)

The drive requirements for this amplifier differ from a standard push-pull amplifier in that the top output tube needs to see a much larger grid swing than the bottom tube. This could be accomplished in the phase splitter by juggling the resistor values or by letting a feedback loop do the work for us, or what would probably work best: a combination of both.

Note, this arrangement does not provide lots of power, just more than single-ended alone. And as most tube push-pull amplifier already run in a rich Class-AB, this modification would only marginally increase the demands on the power supply, but where a the power supply is already over tasked, this modification would require a power supply upgrade.

Solid-state variation

This brings up an interesting thought: what if this addition of a constant current source trick were applied to an existing solid-state amplifier?

It is an old trick to add pull-down resistors to IC Op-Amp outputs, which forces the Op-Amp's normally Class-B output stage to work in Class-A by drawing extra current through its top transistor and thus improving its sonic characteristics. Why not do the same to a power amplifier? Of course, adding a resistor from output to the negative rail would not be the best approach, as the resistor would not draw a constant current.

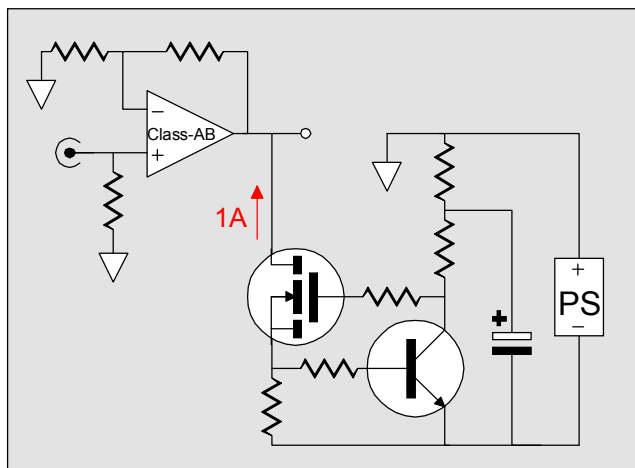

SS Class-A-SE/Class-AB-PP amplifier

A solid-state constant current source could easily be made that would load down the top output transistors or MOSFETs within the amplifier. This extra current draw would have to be matched by the amplifier's top output devices and it would also force the amplifier to cutoff the conduction of its bottom devices as it shifts its driver's DC output voltage higher to increase the top devices' conduction. So in essence, what we have created a Class-A-SE/Class-AB-PP amplifier out of an existing Class-AB amplifier.

This would make the ultimate accessory for our solid-state brethren, as it would force the amplifier to work in single-ended Class-A mode up to 4 watts of output, after which the amplifier would return to push-pull operation. The additional circuitry (including its own power supply) could be housed on its own chassis.

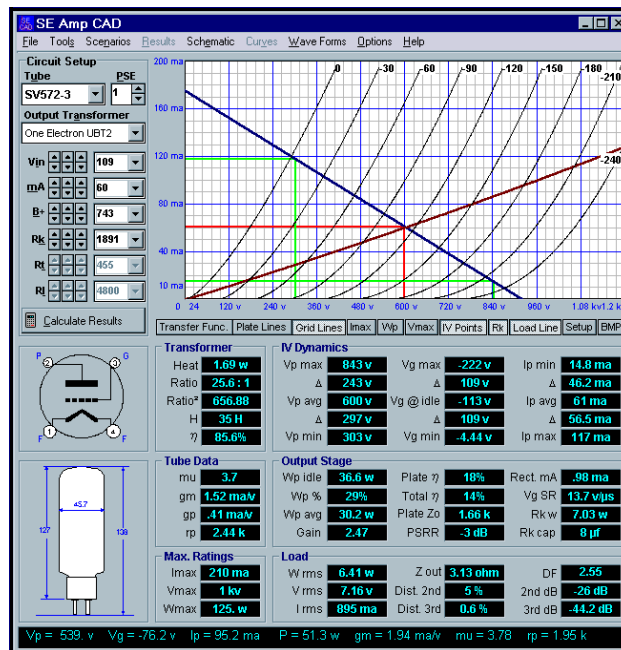

Successful design and analysis of a single-ended amplifier output stage requires an accurate model of the tube's plate curves. SE Amp CAD is a tube audio design program that has a library of 30 tubes and over 100 output transformers and SE Amp CAD knows how these tubes really curve in a singled-ended amplifier.

Windows 9x / Me / NT / 2000

For more information, please visit our Web site or write us at:

GLASSWARE

PO Box 231
Fenton, MI 48430 USA

www.glass-ware.com

Surely, 4 watts of single-ended power is better than any magic stone or \$2000 power cord. And as the circuit would require only two connections to the existing amplifier, most audiophiles could install it. Frosting on this cake would include a temperature sensor to attach to the amplifier's heatsink to monitor the effect of the increased load current. Furthermore, a small high quality fan (i.e. a quiet fan, with serrated blades and quality bearings) could be added to blow on the existing amplifier's heatsink. The self-contained power supply could incorporate a multi-tapped power transformer, which would allow adjusting the power supply voltage to match the amplifier's rail voltage. (Of course, a connection could be made to the amplifier's negative power supply rail, eliminating the need for the independent power supply.) Unfortunately, many amplifier are so flimsily made that the 1A load would cause them to overheat. (Bear in mind that many transistor amplifiers have an output stage idle current of only 50mA, which would make the 1A represent a twentyfold increase in conduction and a tenfold increase in heat dissipation.) One possible work around would be to rewire the power transformer's connections to the line voltage, if the transformer has two primaries.

Amplifier often contain power transformers meant to be used in either 230 VAC or 120 VAC countries. Where 230 VAC is used, the transformer's two primaries are wired in series; where 120 VAC is used, in parallel. Thus if you live in a 120 VAC country, you could wire the primaries in series, halving the power supply rail voltages, but doubling the current delivery capacity. Now, it would be unlikely that the solid-state amplifier's output devices would leave their safe operating area (SOA).

However, such as modification to the power supply could upset the amplifier internal voltage references. But anyone familiar with solid-state circuit design should be able to evaluate the amplifier's suitability in just a few minutes of schematic perusal. However, such a modification would certainly quarter the available output power. But would you rather have four plates of bad food or one plate of tasty food? Another advantage to the lower rail voltage is that the amplifier's electrolytic capacitors should last forever because of the reduced voltages.

All in all, this idea is definitely worth experimenting on. And should anyone experiment along these lines, please share your results with us.

The SA-1 makes a great addition to any audio test bench. It can also be a complete preamp solution for audiophile "purists". Consider the advantages of using a Passive Preamp like the SA-1 between your CD/DVD player(s) and your power amplifier(s): The SA-1 adds no distortion to your signal path while performing the major task of most preamps - signal level control. (Active preamps add in at least *some* distortion.) It uses a precision 24 position stepped attenuator for low noise and excellent channel-to-channel signal level tracking. And it costs a fraction of what an active preamp costs.

Arn Roatcap, Inc.

1248 Valerian Court #4 Sunnyvale, CA 94086
Phone: (408) 737-3920 E-mail: info@goldpt.com



<http://www.goldpt.com>

Phone: (408) 737-3920 E-mail: info@goldpt.com

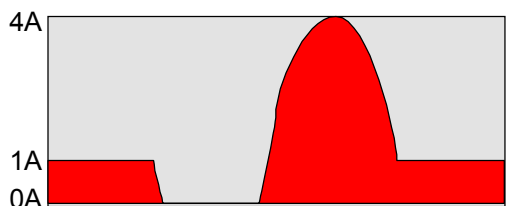

Top Device

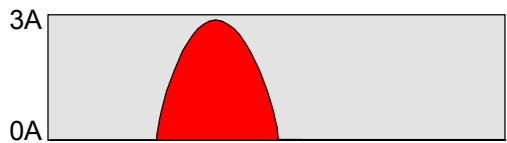

Bottom Device



Constant current source

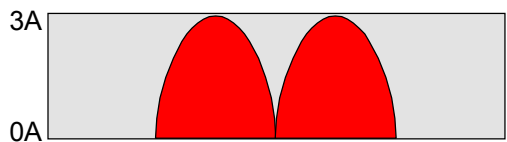

Load

Restoring sonic control

All of the circuits described in this article grant the listener the chance to regain some control over the sound from the amplifiers. Varying the current ratio between output tube pairings allows varying the sonic signature of the amplifier, as triodes, pentodes, ultra-linearly arranged pentodes, single-ended output stages, and push-pull output stage all sound different. In the extreme case, one set of tubes could be entirely turned off completely by disconnecting them from the circuit or by disconnecting their heaters from the power supply. Thus, we could choose between only one type of amplifier style or mode at a time, say single-ended triode for string quartets and push-pull pentode for heavy metal. This option might be seen as the choice between expensive high quality tubes (300Bs or 845s) when listening seriously and cheap powerful tubes when background music is needed. Still, having a variable control in the form of a potentiometer would allow the most adjustment; musicians would be in heaven.

//JRB

The first
Tube CAD Journal
companion
software program



TUBE CAD JOURNAL

Filter Designer

Version 1

GlassWare © Copyright 2001

All Rights Reserved

TCJ Filter Designer lets you design a filter or crossover (passive, solid-state or tube) without having to check out thick textbooks from the library and without having to breakout the scientific calculator. This program's goal is to provide a quick and easy display not only of the frequency response, but also of the resistor and capacitor values for a passive and active filters and crossovers. Tube crossovers are a major part of this program; both buffered and unbuffered tube based filters along with mono-polar and bipolar power supply topologies are covered.

For more information, read the article "[Tube-Based Crossovers](#)" in the *Tube CAD Journal*.
To buy now, visit [GlassWare's new Yahoo! Store](#).