

GlassWare  
AUDIO DESIGN

# SRPP+

All-in-One Stereo 9-Pin PCB

## USER GUIDE

- Introduction
- Overview
- Schematics
- Recommended Configurations
- Tube Lists
- Assembly Instructions

Sept 28 2009

## ⬅️ Warning! ➡️

This PCB contains a high-voltage power supply; thus, a real and lethal shock hazard exists. Once the power transformer is attached, be cautious at all times. In fact, always assume that the high voltage capacitors will have retained their charge even after the power supply has been disconnected or shut down. If you are not an experienced electrical practitioner, before applying the AC voltage have someone who is experienced review your work. There are too few tube-loving solder slingers left; we cannot afford to lose any more.

## Overview

Thank you for your purchase of the GlassWare SRPP+ 9-pin stereo PCB. This FR-4 PCB is extra thick, 0.094 inches (inserting and pulling tubes from their sockets won't bend or break this board), double-sided, with plated-through heavy 2oz copper traces. In addition, the PCB is lovingly and expensively made in the USA. The boards are 6 by 6 inches, with five mounting holes, which helps to prevent excessive PCB bending while inserting and pulling tubes from their sockets.

Each PCB holds two SRPP+ line-stage amplifiers; thus, one board is all that is needed for stereo unbalanced use (or one board for one channel of balanced line-stage amplification). By including the necessary components for the heater and high voltage B+ power supplies on the PCB, the SRPP+ board makes building a line stage or headphone amplifier a breeze. This assembled board with a chassis, volume control, selector switch, power transformer, and a fistful of RCA jacks is all that is needed.

## PCB Features

**B+ and Heater Power Supplies** On the SRPP+ board, two power supplies reside, one for the high-voltage B+ for the tubes and a low-voltage power supply for the heaters. The high-voltage power supply uses an RC filter to smooth away ripple, while the low-voltage power supply uses a voltage regulator to provide a stable and noise-free voltage output. The heater regulator is adjustable and can be set to 6V or 12V. The power supplies require an external power transformer(s) with two secondary windings (120Vac to 260Vac and 12Vac to 12.6Vac).

**Redundant Solder Pads** This board holds two sets of differently-spaced solder pads for each critical resistor, so that radial and axial resistors can easily be used (radial bulk-foil resistors and axial film resistors, for example). In addition, most capacitor locations find many redundant solder pads, so wildly differing-sized coupling capacitors can be placed neatly on the board, without excessively bending their leads.

**Power-Supply-Decoupling Capacitors** The SRPP+ PCB provides space for two sets of capacitors to decouple both SRPP+ gain stages from the B+ connection and each other. This arrangement allows a large-valued electrolytic capacitor and small-valued film capacitor to be used in parallel, while a series voltage-dropping resistor completes the RC filter. (As an option, in place of the series resistors, an off-board chokes can be used.)

## Introduction to the SRPP+ Circuit

In spite of its immense popularity and few circuit elements, few understand how the SRPP circuit works. The first step is to discern just what the SRPP's function is. For example, is it a unity-gain buffer? A voltage amplifier? A phase splitter? An argument could be made for all three answers, but none would prove completely satisfying. Yes, the SRPP appears to encompass a cathode follower of sorts, making the unity-gain buffer answer seem at least partially right. And it does provide gain, making the voltage amplifier answer partially right. And it is capable of swinging positive and negative current swings into a load in excess of its idle current, making push-pull operation and, thus, making a portion of the phase splitter answer seem reasonable. So what is its primary function? The answer is that the SRPP is actually two elemental circuits, not one.

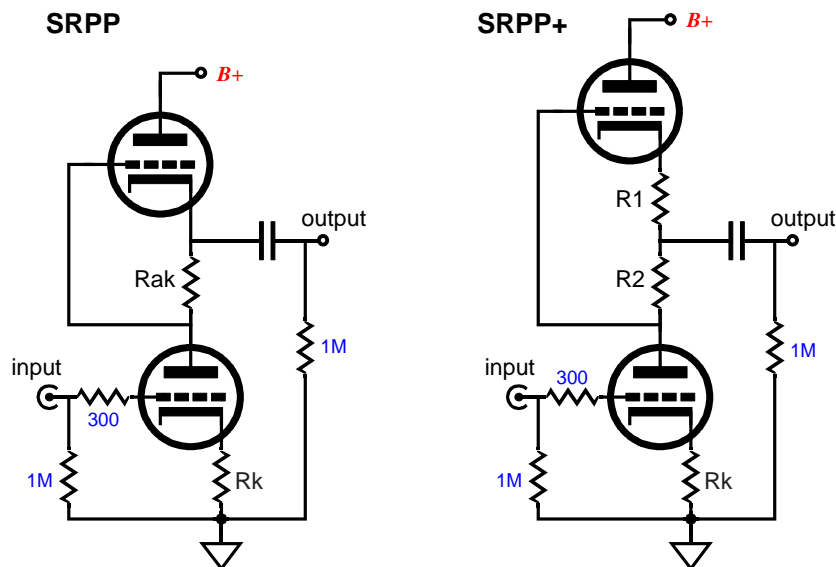

The SRPP is a compound circuit that holds a simple grounded-cathode amplifier that provides voltage gain and an impedance-multiplier that is neither a unity-gain buffer nor voltage amplifier. Two sub-circuits? The bottom triode is configured as a grounded-cathode amplifier that sees its plate loaded by a magnified load impedance provided by the top triode, which is configured as an impedance-multiplier. What is an impedance-multiplier? An impedance-multiplier is a circuit that effectively inflates the impedance presented by the load. An impedance doubler, as an example, doubles the effective impedance of the external load; for example, 300 ohms will be reflected as being 600 ohms. Thus, a 1mA current flow into the impedance-multiplier will not produce the 0.3V voltage drop across the 300-ohm load resistor, but instead 0.6V will develop across the resistor. So as far as the bottom tube in the SRPP is concerned, the 300-ohm load is now a 600-ohm load, which means that greater gain is now realizable by the grounded-cathode amplifier.

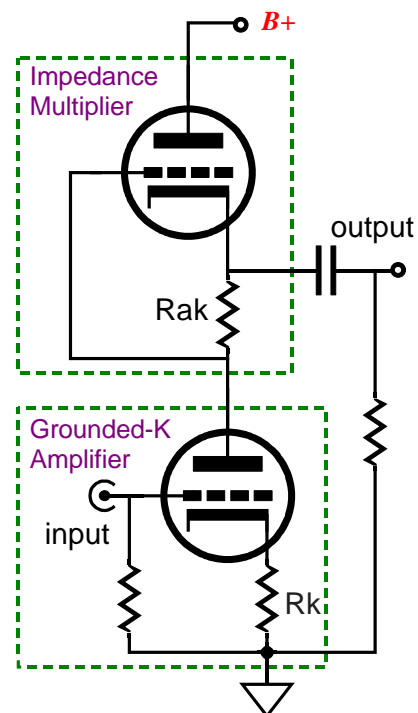

First let's examine a conceptually pure impedance-multiplier. The following may look like a solid-state OpAmp circuit, but think of it as an idealized OpAmp, whose underlying technology is unspecified, but which adheres to the concept of a perfect OpAmp: infinite open-loop gain, infinitely low output impedance, and infinitely wide frequency bandwidth, a true voltage amplifier, one capable of delivering infinite current into a load.

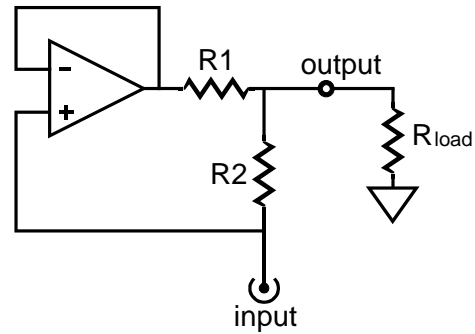

Resistors R1 and R2 set the impedance-multiplication ratio for the circuit. When R1 equals R2, the impedance-multiplier circuit effectively doubles the load impedance. Using 1 ohm for R1 and R2 and an 8-ohm load, let's examine what happens when 1A of positive-going current is applied to the impedance-multiplier's input.

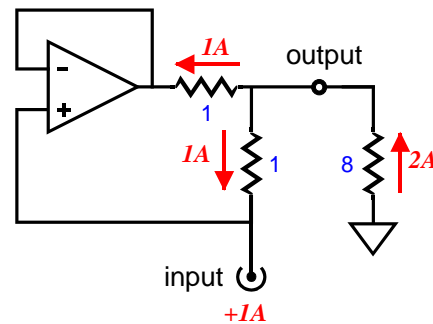
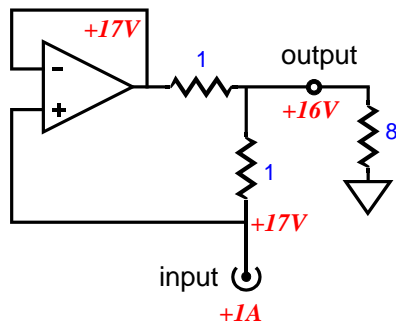

Normally, 1A against 8 ohms equals a voltage drop of 8Vdc, but in our circuit the 8-ohm load sees 16Vdc developed across the resistance. Since the signal source draws 1A, where does the extra 1A of current come from? The super OpAmp strive will all its might to keep both its inputs, the inverting and non-inverting, at the exact same voltage, which, in this example, is only possible when the OpAmp's output voltage equals the input voltage present at the impedance-multiplier's input.

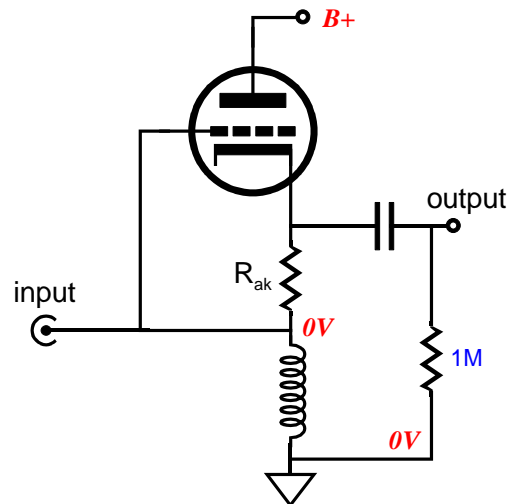
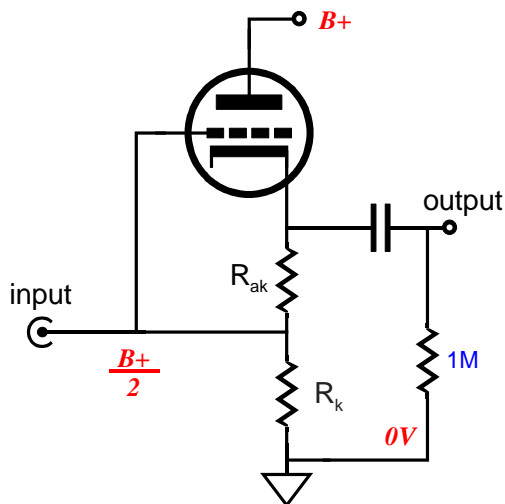

The two above circuits are examples of tube-based impedance-multiplier circuits. The circuit on the left presents a huge DC offset at its input, while the circuit on the right sidesteps the offset by using a perfect inductor, which holds no DCR, so cannot displace any voltage under steady current flow; nonetheless, both function similarly.

Amazingly enough, just one tube and a resistor is all that's needed to create an impedance-multiplier circuit. The idealized OpAmp version would certainly require many more components within the OpAmp and two ratio-setting resistors (R1 & R2) were needed. How does the tube-base version get away with one resistor? The tube-based impedance-multiplier circuit also holds two resistances to fix its impedance-multiplier ratio, but the first resistance (R1) is concealed, as it is implicit in the top tube's output impedance at its cathode, which equals  $r_p/\mu$ , the inverse of its transconductance in other words. This impedance effectively creates the missing R1 resistor. Thus, the only way for R1 to vanish altogether is for the top tube to possess infinite transconductance, but poor little triodes have a hard time mustering a maximum of about 40mA/V of gm. For example, a 6DJ8/6922-based impedance-multiplier circuit holds an implicit R1 of about 100 ohms, as the triode's gm is about 10mA/V. So should Rak's (effectively R2's) value also be set to 100 ohms, thereby creating an impedance-multiplier ratio of 2?

As you might have guessed, because a single triode falls so short of matching an idealized OpAmp—with its low transconductance,  $r_p$ , and limited  $\mu$ —the simple formulas for the idealized impedance-multiplier circuit must be modified to conform to the tube's actual functioning. If the external load were a dead short to ground, then Rak (R2) should be set to  $r_p/\mu$ . But with a load impedance greater than zero the following formula is needed:

$$R_{ak} (R_2) = r_p/\mu + 2R_{load}/\mu$$

In effect, the external load is mitigating the tube's transconductance, so the value of resistor Rak (R2) must be increased by  $2R_{load}/\mu$ . In other words, a different load impedance, a different Rak value. If the triode offered infinite  $\mu$ , one Rak resistor value would work with all load impedances. This means that setting up an SRPP circuit takes much more thought than many solder slingers can marshal, but armed with a calculator and the formula finding the optimal resistor value is not difficult. The actual difficulty occurs when we try to use our correct value in an actual circuit. For example, a 6H30-based impedance-multiplier circuit working into a 32 ohm load requires an Rak value of 73 ohms, which when used with a 100V differential from cathode to plate, will result in an idle current draw of over 40mA, which comes dangerously close to exceeding the tube's dissipation limit. In addition, we may only want to allow 20mA of idle current. The solution to this problem is the SRPP+, as its additional resistor allows us to set the idle current to 20mA and to retain the impedance-multiplier ratio of 2. Resistor Rak has been replaced by two resistors, R1 and R2, in the SRPP+ circuit. The first step is to set value of resistor R1 and R2 combined, as it must match that of the bottom triode's cathode resistor. For example, the 6H30 requires a cathode resistor of 220 to establish an idle current of 20mA with cathode-to-plate voltage of 100V. The next step is to use this value as  $R_k$  in the following formulas:

$$R_2 = r_p/2\mu + R_{load}/\mu + R_k/2$$

$$R_1 = R_k - R_2$$

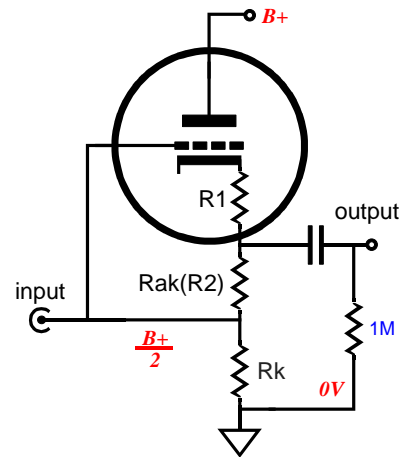

Continuing with the example of a 6H30-based SRPP+ circuit with a 32-ohm load and a B+ of 200V and an idle current of 20mA and Rk equal to 220, resistor R2 should equal 155 ohms and R1, 65 ohms, as the 6H30's rp equals 1310 and its mu equals 15.4 at 20mA at 100V from cathode to plate. In this example, the 32-ohm makes a small contribution; but with a 600-ohm load, the ratio between R1 and R2 changes quite a bit more, as R2 would equal 172 and R1, 48 ohms.

The idealized OpAmp-based impedance-multiplier circuit can swing both huge voltage and current swings into a load while dissipating no heat at idle, running as it does in perfect class-B mode; it is ideal, after all. The tube-based SRPP and SRPP+ circuit is not so lucky, as it must run its internal impedance-multiplier circuit in a strict push-pull, class-A mode, wherein the peak output current equals twice the idle current. If the bottom triode cuts off completely, it can no longer steer the top triode.

Interestingly, the bottom triode's impedance at its plate only influences the impedance-multiplier circuit's output impedance, but has no effect on the R1 and R2 values, even if the bottom triode were replaced by a pentode. The bottom tube's impedance at its plate will alter the output impedance seen by the load. The lower the impedance at the plate, the lower the output impedance. The plate-load impedance seen by the bottom triode is equal to  $2R_{load} + R_2$ , which allows us to compose the formula for the gain of an SRPP+ circuit, wherein the bottom triode's cathode resistor is bypassed (or replaced with an LED) and the load is substantially lower than the triode's rp.

$$\text{Gain} = \mu(2R_{load} + R_2) / (2R_{load} + R_2 + r_p)$$

With the cathode resistor left unbypassed (much better sounding),

$$\text{Gain} = \mu(2R_{load} + R_2) / (2R_{load} + R_2 + r_p + [\mu + 1]R_k)$$

When the load impedance is high, the gain equals roughly  $\mu/2$ . The SRPP+ performs best at driving fairly low impedances, however, as it functions like a small push-pull voltage/current amplifier of sorts. An ideal load would be a 600-ohm L-pad or series attenuator or low-input-impedance solid-state power amplifier, such as the Zen, or headphones with a flat-impedance plot.

In fact, a small 1W OTL power amplifier could be made if a 600-ohm loudspeaker were used. (These speakers were once made for Ham radio use.) Or with a 600:8 ohm step-down output transformer, the mighty 1W OTL could power 8-ohm loudspeakers. The obvious alternative is headphones, as many great-sounding headphones come with 250-2k impedances that preclude their use with most MP3 players, most of which were designed with 16-32 ohm headphones in mind.

(If the load impedance is not flat, however, the SRPP+ relatively high output impedance will result in a non-flat output, as the impedance rises, so will the output, as the impedance drops, so will the output.)

## B-Plus Power Supply

The high voltage B-plus power supply resides on the SRPP+ PCB. It contains a full-wave bridge rectifier circuit and reservoir capacitor, which is then followed by an RC-smoothing filter. The high voltage power transformer is external to the PCB and can be mounted in, or outside, the chassis that houses the PCB.

The optimal B-plus voltage depends on the tubes used. For example, 6GM8s (ECC86) can be used with a low 24V power supply, while 6DJ8s 6H30s work better with a 150V to 240V B-plus voltage; 6CG7s and 12BH7s, 200V to 300V. The sky is not the limit here, as the power supply capacitors and the heater-to-cathode voltage set an upward limit of about 350V for the power supply voltage after the rectifiers and about 300V at the tubes after the RC filter.

Resistors R9a & R9b with capacitors C4 & C5 define the RC power supply filters. Resistor heat equals  $I^2 \times R$  (and  $V^2/R$ ); for example, 20mA into 5k will dissipate 2W. See page 14 for more information. Several goals that work against each other: we want the largest voltage-dropping resistor value possible, as it reduces the ripple SRPP+ 's power supply connection; and we want the smallest value for R9, as this resistor limits the maximum idle current that can flow through the SRPP+ stage; and we want the lowest raw B-plus voltage possible, as it will allow a larger-valued reservoir capacitor and limit the heater-to-cathode voltage; and we want the highest plate voltage possible for the tubes, as it makes for better sound. We cannot have it all. Choices must be made and consequences must be accepted.

An analogy can be made between cars and a tube line-stage amplifier. A race car runs high revs and high horsepower and it is obscenely expensive, noisy, unreliable, and glorious to behold. A family's commuter car is cheap, quiet, reliable, and boring. Running high voltage and high current will make for a short tube life and a wonderful sound. Running low voltage and low current will greatly extend tube life and save money on part cost. For example, a typical 250V capacitor is much more volumetrically efficient and cheaper than a 400V capacitor. Thus, running a lower B-plus voltage allows us to increase greatly the total capacitance in the power supply, at a lower cost.

### Typical Part Values

( ) Parentheses denote recommended values

**C4** = 0.1µf to 1µF\* (0.47µF 400V)

**C5** = 47µF to 470µF\* (150µF 400V)

**C7** = 33µF to 100µF\* (33µF 450V)

**C17** = 0.01µF to 0.47µF  $\geq$  100V

\*Voltage depends on transformer used; all must exceed the B+ voltage.

**D1-4** = 1N4007, UF4007, HEXFRED (HER108)

**R9** = 100 to 20k

**R10-13** = 10 1W

**R15** = 300k 1W

**R14** = 50k to 100k 1W

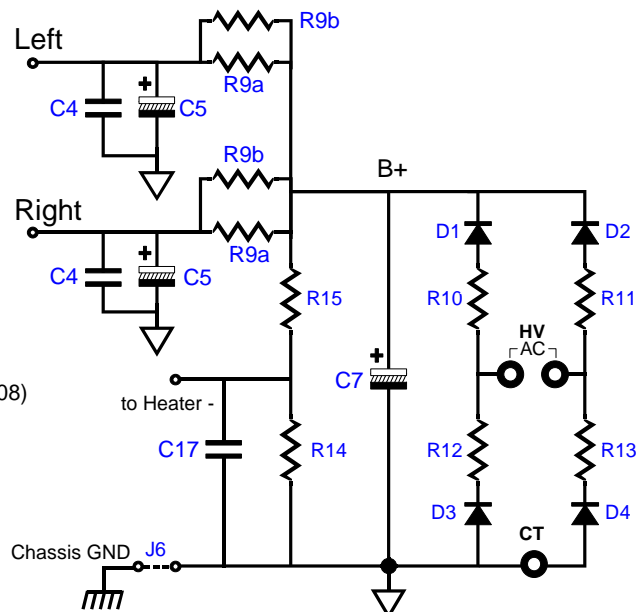

## Power Transformer(s)

The SRPP+ PCB requires a power transformer(s) to energize its two power supplies. The heater power supply power transformer must offer at least 1.8 times more current than the heaters will draw. For example, two 6CG7s will draw 0.6A @12.6v, so the heater power transformer must be able to sustain an AC 1.08A current draw. In addition, with sine waves, the AC voltage equals the peak voltage divided by the square root of 2, i.e. 1.414. Thus, a 10Vac sine wave peaks at 14.14V; a 6.3Vac, 8.9V. In other words, a sine wave that peaks at 14.14V will produce the same amount of heat in a resistance as a 10Vdc voltage source would produce in the same resistance; thus, we label the 14.14Vpk sine wave as being 10Vac. Thus, in order to get the 16Vdc a 12.6V heater voltage regulator requires an input voltage equal to sum of 16V and the rectifier loss (about 2V) divided by 1.414, which is roughly 12.6Vac.

The high voltage power transformer must also follow the same rules. Thus, to achieve 300V of raw DC voltage, the transformer primary must deliver  $(300V + 2V) / 1.414$ , or about 214Vac. And if 50mA is required, the power transformer must be rated for 50mA x 1.8, or about 90mA. Such a transformer VA rating would equal 33VA.

A center-tapped primary can be used; just leave D3, D4, R12, and R13 off the board, then attach the transformer center-tapped lead to the CT pad.

## Configuring a Headphone Amplifier

The SRPP+ topology makes a sweet little headphone amplifier, as it offers large out swings into low impedance loads—without a global feedback loop. On the other hand, a feedback loop could be added by adding two resistors per channel, in the classic inverting-amplifier arrangement, wherein a resistor is placed in series with the input signal and the bottom triode's grid and a feedback resistor spans from the same grid to the output, after the coupling capacitor. Such an arrangement might be perfect for use with an MP3 player, as +6dB of gain is all that is needed with most headphones.

### Typical Part Values

Tube =	6CG7	6DJ8	6H30	6H30	12BH7
<b>B+ Voltage =</b>	250V	200V	150V	250V	300V
<b>Heater Voltage =</b>	6.3V or 12.6V	6.3V or 12.6V	12.6V	12.6V	12.6V
<b>R1, 6 =</b>	1M	Same	Same	Same	Same
<b>R2 =</b>	417* (6.3mA)	200* (10mA)	100* (25mA)	300* (20mA)	30 0* (14mA)
<b>R3, 7 =</b>	300*	Same	Same	Same	Same
<i>with 32-ohm HP</i>					
<b>R4 =</b>	Not recommended	50*	12*	103*	Jumper
<b>R5 =</b>	Not recommended	150*	88*	197*	240*
<i>with 300-ohm HP</i>					
<b>R4 =</b>	Jumper	40*	Jumper	85.6*	13*
<b>R5 =</b>	417	160*	110	215*	287*

\*High-quality resistors essential in this position. All resistors 1/2W or higher

<b>C1 (32-ohm HP) =</b>	Not recommended	30µF*	Same	Same	Same
<b>C1 (300-ohm HP) =</b>	10µF	10µF*	"	"	"
<b>C2 =</b>	47 - 1k µF/16V (optional)	"	"	"	"
<b>C3 =</b>	0.1 - 1µF/16V (optional)	"	"	"	"
<b>C4 =</b>	0.1 - 1µF* Film or Oil	"	"	"	"
<b>C5 =</b>	47-470µF*	"	"	"	"
<b>C6 =</b>	0.01-0.47µF (optional)	"	"	"	"

\*Voltage rating must equal or exceed B+ voltage

<b>V1, V2 =</b>	6CG7, 6FQ7 12FQ7	6DJ8, 7DJ8, 6922, 7308, E88CC	6H30	6H30	ECC99
-----------------	---------------------	----------------------------------	------	------	-------

### Tube Selection

The SRPP+ is quite flexible, as a SRPP+ can be built using many different tubes. In general, low- $r_p$  should be used, such as the 6CG7, 6DJ8, 6H30, 12AU7, 12BH7, and ECC99 are the obvious choices, but other twin-triodes can be used. For example, even a 12AX7 could find use with the right load impedance. In other words, the list of possible tubes is a long one: 6AQ8, 6BC8, 6BK7, 6BQ7, 6BS8, 6DJ8, 6FQ7, 6GC7, 6H30, 6KN8, 6N1P, 12AT7, 12AU7, 12AV7, 12AX7, 12BH7, 12DJ8, 12FQ7, 5751, 5963, 5965, 6072, 6922, E188CC, ECC88, ECC99... The only stipulations are that the two triodes within the envelope be the same and that the tube conforms to the 9A or 9AJ base pin-out. Sadly, the 12B4 and 5687 cannot be used with this PCB.

### Internal Shields

If the triode's pin 9 attaches to an internal shield, as it does with many NOS 6CG7s and all 6DJ8s, then capacitors C1 and C2 can be replaced with a jumper wire, which will ground the shield. However, using the capacitors rather than jumpers will also ground the shield (in AC terms).

### Cathode Resistor Values

The cathode resistor and plate voltage set the idle current for the triode: the larger the value of the resistor, less current; the higher the plate voltage, more current. In general, high- $\mu$  triodes require high-value cathode resistors (1-2K) and low- $\mu$  triodes require low-valued cathode resistors (100-1k). The formula for setting the  $I_q$  is an easy one:

$$I_q = B+/2(r_p + [\mu + 1]R_k)$$

So, for example, a 6DJ8 in a SRPP+ with a B+ voltage of +170V and 100-ohm cathode resistors will draw  $170/2(3k + [31 + 1]100)$  amperes of current, or 13.7mA (actual mileage will vary, as they say in the car ads, but this formula will get you close).

### Coupling-Capacitor Values

The bigger in value the coupling capacitor, the lower the -3dB high-pass corner frequency will be. The formula is as follows:

$$\text{Frequency} = 159155/C/R$$

where C is in  $\mu\text{F}$  and R includes the SRPP+'s output impedance. For example, with a  $30\mu\text{F}$  coupling capacitor and a headphone with an impedance of 600 ohms, the corner frequency would be 8.8Hz. The higher the load impedance, the lower the corner frequency. The coupling capacitor voltage rating must at least equal the B+ voltage, for safety's sake. Pads are provided for bypass capacitors, C15, for the coupling capacitors.

### Calculating $Z_o$

In spite of the SRPP+ ability to swing burly amounts of current into fairly low load impedances, its output impedance is much higher than we might expect. With resistor  $R_k$  bypassed by a large-valued capacitor, the formula reads:

$$Z_o = (\mu + 1)R_k + r_p \parallel r_p \parallel \frac{r_p + R_2}{R_2} \times \left( \frac{r_p}{\mu} + R_1 \right)$$

---

## Assembly & Testing

**Assembly** Cleanliness is essential. Before soldering, be sure to clean both sides the PCB with 90% to 99% isopropyl alcohol. Do not use dull-looking solder; solder should shine. If it doesn't, first clean away the outer oxidation with some steel wool or a copper scouring pad. If the resistor leads look in the least gray, clean away the oxidation with either steel wool or a wire sniper's sharp edges. Admittedly, with new resistors and a fresh PCB, such metal dulling is rare; but if the parts have sat in your closet for a year or two, then expect a good amount of oxidation to have developed.

First, solder all the small diodes in place, and then solder the resistors, rectifiers, capacitors, and heatsinks. Be consistent in orienting the resistors; keep all the tolerance bands on the resistor's body at the right side as you face the resistor straight on. This will pay dividends later, if you need to locate a soldered a resistor in the wrong location. Because the board is double sided, with traces and pads on each side, it is easier to solder the resistors from their top side. It is often easier to attach the LD1085 (heater regulator) to its heatsink first (using the heatsink hardware kit) and then to solder both the heatsink and regulator to the PCB at once. As the PCB is so overbuilt, it is extremely difficult to remove an incorrectly placed part. Be sure to confirm all the electrolytic capacitor orientations, as a reversed polarized capacitor can easily vent (or even explode) when presented with high-voltage. Confirm twice, solder once.

**Testing** Before testing, visually inspect the PCB for breaks in symmetry between left and right sides. Wear safety eye goggles, which is not as pantywaist a counsel as it sounds, as a venting power-supply capacitor will spray hot caustic chemicals. Make a habit of using only one hand, with the other hand behind your back, while attaching probes or handling high-voltage gear, as a current flow across your chest can result in death. In addition, wear rubber-soled shoes and work in dry environment. Remember, safety first, second, and last.

1. Attach only the heater power supply's transformer winding, leaving the high-voltage transformer leads unattached and electrical tape shrouded, with no tubes in their sockets.
2. Use a variac and slowly bring up the AC voltage, while looking for smoke or part discoloration or bulging.
3. Measure the heater regulator's output voltage without and with a load. If the heater regulator fails to regulate, try either lowering the heater voltage a tad, for example 12V instead of 12.6V, as the 0.6V difference might be enough to bring the regulator back into regulation.
4. Next, power down the heater regulator and attach the high-voltage windings and insert the tubes in their sockets.
5. Attach the transformer to a variac and slowly bring up the AC voltage.
6. Measure the voltage across ground and B-plus pads in the center of the PCB; then measure the voltage across capacitors, C4 & C5. If the two channels differ by more than 10Vdc, try switching tubes from one channel to the other. If the imbalance does not follow the tubes, there is a problem, probably a misplaced part.

Only after you are sure that both heater and B-plus power supplies are working well, should you attach the line-stage amplifier to a power amplifier.

## Grounding

The SRPP+ PCB holds a star ground at its center. Ideally, this will be the only central ground in the line-stage amplifier. Ground loops, however, are extremely easy to introduce. For example, if the RCA jacks are not isolated from the chassis, then the twisted pair of wires that connect the PCB to the jacks will each define a ground loop (as will jumper J6, which bridges the PCB's ground to the chassis). The solution is either to isolate the jacks or use only a single hot wire from jack to PCB (the wire can be shielded, as long as the shield only attaches at one end). Thus, the best plan is to plan. Before assembling the line-stage amplifier, stop and decide how the grounding is going to be laid out, then solder.

Three different schools of thought hold for grounding a piece of audio gear. The Old-School approach is to treat the chassis as the ground; period. Every ground connection is made at the closest screw and nut. This method is the easiest to follow and it produces the worst sonic results. Steel and aluminum are poor conductors.

The Semi-Star ground method uses several ground "stars" that are often called spurs, which then terminate in a single star ground point, often a screw on the chassis. This system can work beautifully, if carefully executed. Unfortunately, often too much is included in each spur connection. For example, all the input and output RCA jacks share ground connection to a long run of bare wire, which more closely resembles a snake than a spur ground. In other words, the spurs should not be defined just physical proximity, but signal transference. Great care must be exercised not to double ground any spur point. For example, the volume control potentiometer can create a ground loop problem, if both of its ground tabs are soldered together at the potentiometer and twisted pairs, of hot and cold wires, arrive at and leave the potentiometer, as the two cold wires attaching to the PCB will define a ground loop.

The Absolute-Star grounding scheme uses a lot of wire and is the most time consuming to execute, but it does yield the best sonic rewards. Here each input signal source and each output lead gets its own ground wire that attaches, ultimately, at one star ground point; each RCA jack is isolated from the chassis. The SRPP+ PCB was designed to work with this approach, although it can be used with any approach.

**House Ground** The third prong on the wall outlet attaches to the house's ground, usually the cold water pipe. The line-stage amplifier can also attach to this ground connection, which is certainly the safest approach, as it provides a discharge path should the B+ short to the chassis. Unfortunately, this setup often produces a hum problem. Some simply float the ground, others use several solid-state rectifiers in parallel to attach the chassis ground to the house ground (**NOT NEUTRAL**) via the third prong, and others still use a 10-ohm/10W resistor shunted by a small capacitor, say 0.001 $\mu$ F to 0.1 $\mu$ F/400V.

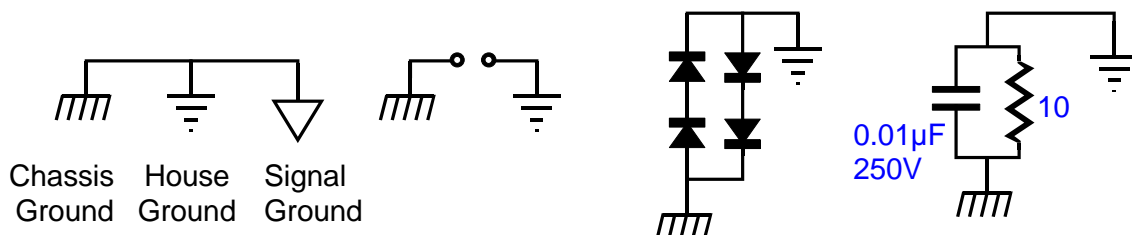

A good test procedure is to detach all the signal inputs and all the output connection from the line-stage amplifier. Then measure the AC voltage between the line-stage amplifier's chassis and the house's ground. If it reads more than a few volts, try reversing the line-stage amplifier's plug as it plugs into the wall socket. Use which ever orientation that results in the lowest AC voltage reading. Then measure the chassis ground to the first signal source's ground (while the signal source is turned on). Once again flip the signal source's plug until the lowest AC voltage setting is found. Then do the rest with the rest of the system. The results can prove far more satisfying than what would be yielded by buying thousand-dollar cables.

**RFI** Radio frequency interference can be a hassle to track down and eliminate. First make sure that the source of the problem actually resides in the line-stage amplifier. For example, if only one signal source suffers from RFI noise, make sure that it is normally RFI free. In other words, attach it to another line-stage amplifier and see if the RFI persists. If it does pass this test, then try soldering small capacitors, say 100pF, from this signal source's RCA jacks to the chassis, as close as possible to the jacks: if it fails, fix the source.

Ferrite beads can also help; try using beads on the hot lead as it leaves the RCA jack and then again at the selector switch. Increasing the grid-stopper resistor's (R2) value, say to 1k, can also work wonders (use a carbon-composition or bulk-foil resistor or some other non-inductive resistor type).

**Terminating Resistors** Here's a cheap trick to try: at each input RCA jack, place a 100k to 1M resistor, bridging input hot and jack ground. Why? The resistor provides a path for the AC signal present at the jack, so given a choice between radiating into the chassis or going through the relatively low-impedance resistor, the AC signal chooses the latter path, reducing crosstalk.

**Chassis Ground** Jumper J6 connects the PCB's ground to the chassis through the top leftmost mounting hole. If you wish to float the chassis or capacitor couple the chassis to ground, then either leave jumper J6 out or replace it with a small-valued capacitor (0.01 to 0.1 $\mu$ F). Warning: if rubber O-rings are used with PCB standoffs, then the ground connection to the chassis is not likely to be made; tubes, use metal washer in place of top O-ring.

**CATV Ground** Attaching a line-stage amplifier to TV or VCR can cause huge hum problems, as the "ground" used by the connection CATV connection may introduce hum. Isolation transformers work supremely well in this application. In fact, an isolation transformer can be used on all the input signals only (one transformer per channel is required, if it is located after, rather than before the selector switch.) Look on the Web for more complicated solutions to the CATV hum problem.

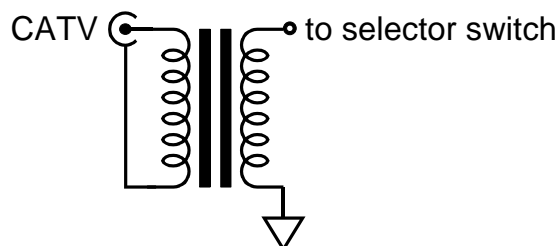

### RC Power-Supply Filter

Resistors R9a and R9b are in parallel. The SRPP+ kit supplies six pairs of 3W resistors for R9 use: 1.6k, 2k, 3k, 3.9k, 6.8k, and 10k. Each resistor can be used in isolation or in parallel with one other resistor. Twenty-one possible combinations are possible; the resulting parallel resistance is shown in the chart below. The charts that follow show the voltage drop across the R9 versus the current flow. Remember each channel gets its own pair of R9 resistors. For example, a SRPP+ amplifier might run each tube with 10mA of idle current, which is also the total for each channel. So by looking up the 10mA column, we can see the resulting voltage drops. Thus, one 3k resistor will drop 30V, so a 280Vdc raw DC power supply will deliver 250Vdc to the tubes. An \* denotes excessive current or voltage, so that combination cannot be used without risking damaging the at least one of the resistors.

R	R9a	R9b	I max mA	V max	W attage	F3 150µF	F3 270µF
889	1600	2000	78	69	5.4	1.19	0.66
1043	1600	3000	66	69	4.6	1.02	0.56
1135	1600	3900	61	69	4.2	0.94	0.52
1295	1600	6800	53	69	3.7	0.82	0.46
1379	1600	10000	50	69	3.5	0.77	0.43
1600	1600	none	43	69	3.0	0.66	0.37
1200	2000	3000	64	77	4.9	0.88	0.49
1322	2000	3900	58	77	4.5	0.80	0.45
1545	2000	6800	50	77	3.8	0.69	0.38
1667	2000	10000	46	77	3.6	0.64	0.35
2000	2000	none	39	77	3.0	0.53	0.29
1696	3000	3900	56	95	5.3	0.63	0.35
2082	3000	6800	46	95	4.3	0.51	0.28
2308	3000	10000	41	95	3.9	0.46	0.26
3000	3000	none	32	95	3.0	0.35	0.20
2806	3900	10000	38	108	4.2	0.38	0.21
3900	3900	none	28	108	3.0	0.27	0.15
2479	3900	6800	44	108	4.7	0.43	0.24
6800	6800	none	21	143	3.0	0.16	0.09
4048	6800	10000	35	143	5.1	0.26	0.15
10000	10000	none	14	170	3.0	0.11	0.06

R	Voltage Drop Against Current															
	9	11	12	14	16	18	20	21	23	25	27	28	30	32	34	36
889	9	11	12	14	16	18	20	21	23	25	27	28	30	32	34	36
1043	10	13	15	17	19	21	23	25	27	29	31	33	35	38	40	42
1135	11	14	16	18	20	23	25	27	29	32	34	36	39	41	43	45
1200	12	14	17	19	22	24	26	29	31	34	36	38	41	43	46	48
1295	13	16	18	21	23	26	28	31	34	36	39	41	44	47	49	52
1322	13	16	19	21	24	26	29	32	34	37	40	42	45	48	50	53
1379	14	17	19	22	25	28	30	33	36	39	41	44	47	50	52	55
1545	15	19	22	25	28	31	34	37	40	43	46	49	53	56	59	62
1600	16	19	22	26	29	32	35	38	42	45	48	51	54	58	61	64
1667	17	20	23	27	30	33	37	40	43	47	50	53	57	60	63	67
1696	17	20	24	27	31	34	37	41	44	47	51	54	58	61	64	68
2000	20	24	28	32	36	40	44	48	52	56	60	64	68	72	76	x
2082	21	25	29	33	37	42	46	50	54	58	62	67	71	75	79	83
2308	23	28	32	37	42	46	51	55	60	65	69	74	78	83	88	92
2479	25	30	35	40	45	50	55	59	64	69	74	79	84	89	94	99
2806	28	34	39	45	51	56	62	67	73	79	84	90	95	101	107	x
3000	30	36	42	48	54	60	66	72	78	84	90	x	x	x	x	x
3900	39	47	55	62	70	78	86	94	101	x	x	x	x	x	x	x
4048	40	49	57	65	73	81	89	97	105	113	121	130	138	x	x	x
6800	68	82	95	109	122	136	x	x	x	x	x	x	x	x	x	x
10000	100	120	140	x	x	x	x	x	x	x	x	x	x	x	x	x
mA	10	12	14	16	18	20	22	24	26	28	30	32	34	36	38	40

## Heater Issues

The SRPP+ PCB holds the heater raw power supply and low-voltage voltage regulator. The regulator uses the LD1085, a low-dropout, adjustable, voltage regulator. The regulator can be set to an output voltage between 6V to 25V, but the assumption is that a 12.6Vdc output voltage will be used for the heaters, so that 6.3V heater tubes (like the 6FQ7 and 6DJ8) or 12.6V tubes (like the 12AU7 or 12BH7) can be used by just switching jumper wires. Thus, for example if the tubes (V1 and V2) are 6CG7s or 6DJ8s and the regulator output voltage is 12Vdc, then use jumper J2 only; if the tubes are 12-volt types, such as the 12AU7 or 12BH7, then the regulator output voltage must be either 12Vdc or 12.6V and use jumpers J1 and J3 only.

Although the preferred power supply voltage is 12V, a 6Vdc (or 6.3Vdc) heater power supply can be used with the PCB, as long as all the tubes used have 6.3V heaters (or a 5V or 8V power supply can be used, if all the tubes share the same 5V or 8V heater voltage). Just use jumpers J1 and J3 only. Note: Perfectly good tubes with uncommon heater voltages can often be found at swap meets, eBay, and surplus stores for a few dollars each, such as the 7DJ8 and 8CG7. Think outside 6.3V box.

**AC Heaters** An AC heater power supply (6.3V or 12.6V) can be used, if the heater rectifiers, power supply capacitors, and regulator are all left off the board. This is not in the least recommended, as the high-current AC voltage will introduce hum and compromise the bass reproduction.

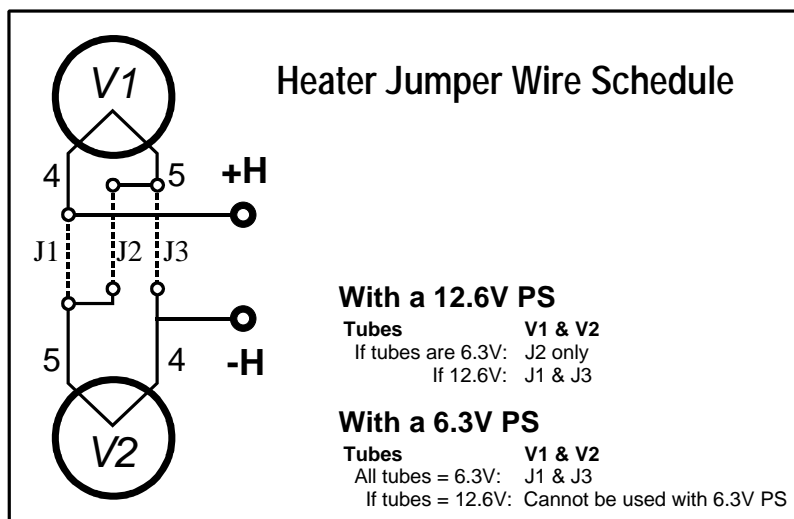

Since one triode stands atop another, the heater-to-cathode voltage experienced differs between triodes. Unfortunately, the compound that is used to isolate the heater element from the cathode structure is extremely thin, which greatly limits the voltage differential that can safely coexist with the cathode and the heater. For most common twin-triode tubes that voltage limit is 90V.

The safest path is to reference the heater power supply to a voltage equal to one fourth the B+ voltage; for example, 75V, when using a 300V power supply. The  $\frac{1}{4}$  B+ voltage ensures that both top and bottom triodes see the same magnitude of heater-to-cathode voltage differential. The easiest way to set this voltage relationship up is the following circuit:

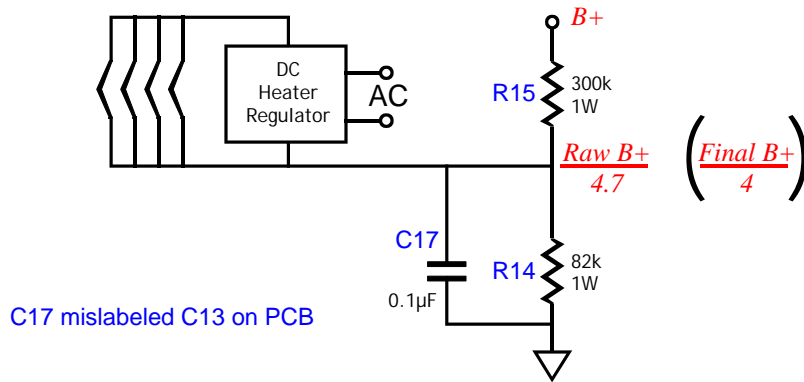

The heater's PS reference bias voltage to target is one quarter of the B-plus voltage that the tubes use, not the initial raw B-plus voltage at the high voltage rectifiers. This means that resistors R14 and R15 values must be experimentally selected. Alternatively, you might experiment with floating the heater power supply, by "grounding" the heater power supply via only a 0.1µF film or ceramic capacitor, leaving resistors R14 and R15 off the board. The capacitor will charge up through the leakage current between heater and cathodes. Not only is this method cheap, it is often quite effective in reducing hum with certain tubes.

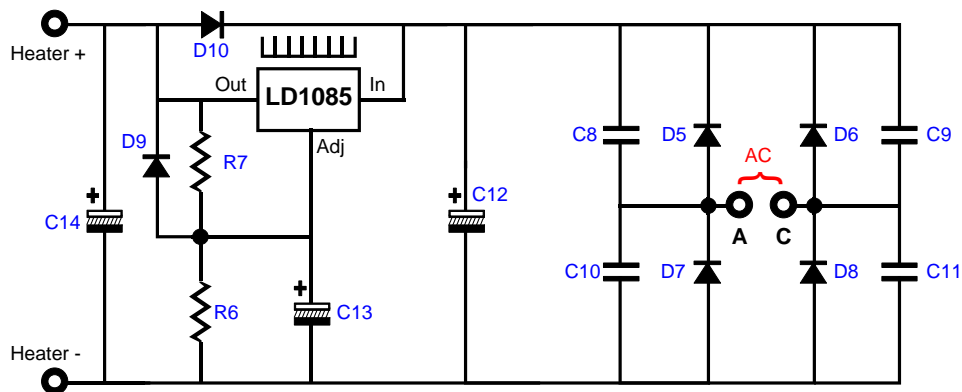

### Typical Part Values

Heater Voltage =	6V	6.3V	8V	12V	12.6V
R8 =	470	499	670	1.07k	1.13k
R7 =	124	same	same	same	same
D5 - D8 =	MUR410G	"	"	"	"
D9, 10 =	1N4007	"	"	"	"
C8, 9, 10, 11 =	1000pF - 1kV	"	"	"	"
C12 =	10µF - 16V*	"	"	"	"
C13, 14 =	1µF - 16V*	"	"	"	"
Regulator =	LD1085, LM317, LM350, LT1085				
Vac Input =	7-8Vac @ 5A for 6.3Vdc 12-12.6Vac @ 2.5A for 12Vdc or 12.6Vdc				

Resistors R7 and R8 set the heater voltage regulator's output voltage. The formula is

$$V_o = 1.25(1 + R_8 / R_7)$$

Thus, using a 125-ohm resistor for R7 and a 2.4k resistor in R8 position, the output will climb to 25.2Vdc. See the values table above.

## Top Side PCB Mechanical Layout

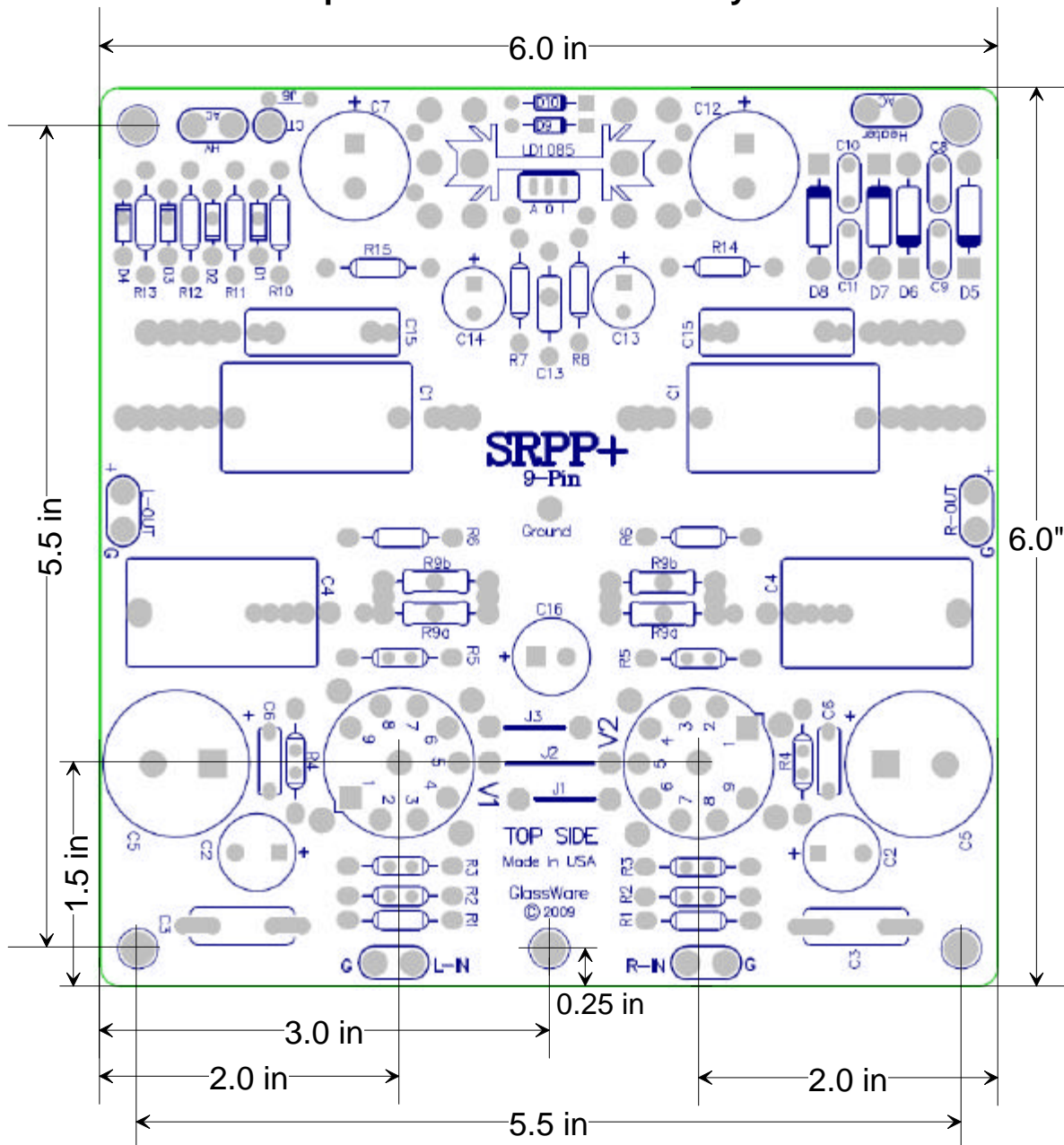

### Let me know what you think

If you would like to see some new audio PCB or kit or recommend a change to an existing product or if you need help figuring out the heater jumper settings or cathode resistor values, drop me a line by e-mail to the address on the back cover (begin the subject line with "tube" or the spam filters are sure to eat your message).

### 9-Pin Tube Data

Tube	B+ (V)	Ik(mA)	mu	rp	Rk
6AQ8	300	10.0	57	9700	100
6BK7	300	10.0	43	4600	200
6BQ7	300	10.0	38.00	5900	191
6BS8	300	10.0	36.00	5000	220
6CG7	150	3.0	20.50	10200	583
6CG7	200	5.0	21.10	8960	397
6CG7	250	5.0	21.00	9250	626
6CG7	300	4.5	20.80	9840	1000
6CG7	300	7.3	21.40	8370	470
6CG7	300	10.0	21.90	7530	243
6CG7	350	10.0	21.80	7680	352
6DJ8	100	5.0	30.20	3670	182
6DJ8	150	10.0	30.70	2870	124
6DJ8	200	10.0	30.00	2960	205
6DJ8	250	10.0	29.60	3060	291
6DJ8	250	5.0	28.60	3980	673
6DJ8	300	5.0	28.30	4080	845
6DJ8	300	8.0	28.90	3400	481
6FQ7	See 6CG7				
6GM8	24	2.0	14.00	3400	187
6H30	100	20.0	15.40	1140	69
6H30	150	30.0	15.9	1040	74
6H30	200	20.0	15.40	1310	221
6H30	250	20.0	15.40	1380	294

Tube	B+ (V)	Ik(mA)	mu	rp	Rk
6H30	300	15.0	15.00	1670	530
6N1P	200	3.0	39.8	12200	328
6N1P	250	5.0	36.00	9480	221
6N1P	300	5.0	35.00	956	642
6N27P	24	2.0	14.00	3400	187
9AQ8	See 6AQ8				
12AT7	200	3.7	60.00	15000	270
12AU7	100	2.5	17.00	9560	427
12AU7	150	3.0	16.60	9570	741
12AU7	200	4.0	16.70	9130	768
12AU7	250	8.0	17.90	7440	336
12AU7	300	10.0	18.10	7120	328
12AV7	200	9.0	37.00	6100	120
12AV7	300	18.0	41.00	4800	56
12AZ7	See 12AT7				
12AX7	200	0.5	100.00	80000	2000
12AX7	300	1.0	100.00	62500	1100
12BH7	100	4.0	16.10	5480	340
12BH7	150	4.0	15.70	6090	706
12BH7	200	5.0	15.90	6140	787
12BH7	250	10.0	17.40	4870	383
12BH7	300	15.0	18.40	4300	267
12BZ7	300	2.0	100.00	31800	550
12DJ8	See 6DJ8				

### SRPP+ Schematic

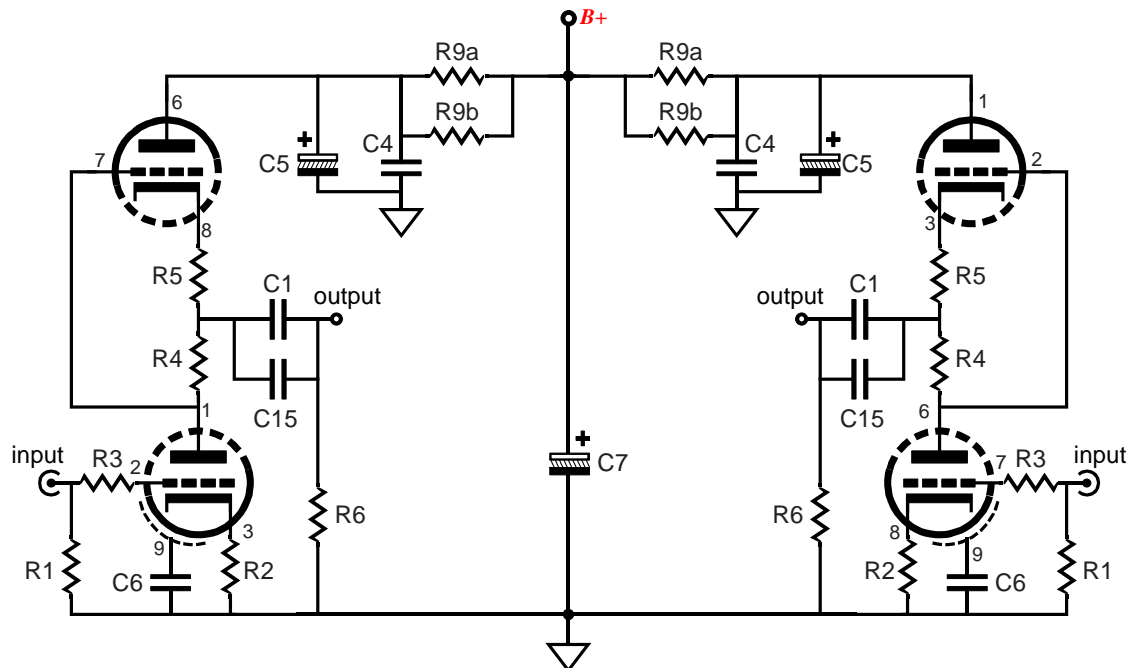

# DANGER!

This PCB holds a high-voltage power supply; thus, a real—and possibly—lethal shock hazard exists.

Ideally, a variac should be used to slowly power up the regulator, as it is better to have a mis-oriented electrolytic capacitor or a mis-located resistor blow at low voltages, rather than at high voltages. Remember that the danger increases by the square of the voltage; for example, 200 volts is four times more dangerous than 100 volts and 400 volts is sixteen times more dangerous.

Once the power supply is powered up, be cautious at all times. In fact, even when the power supply is disconnected or shut down, assume that power-supply capacitors will have retained their charge and, thus, can still shock. If you are not an experienced electrical practitioner, before attaching the transformer windings to the board, have someone who is well-experienced in electronics review your work.

There are too few tube-loving solder slingers left; we cannot afford to lose any more.

**GlassWare**

**AUDIO DESIGN**

[www.glass-ware.com](http://www.glass-ware.com)

[www.tubecad.com](http://www.tubecad.com)

[sales@glass-ware.com](mailto:sales@glass-ware.com)

Copyright © 2009  
All Rights Reserved