

# Aikido

Aikido Stereo 9-Pin PCB

Revision C

## **USER GUIDE**

Introduction  
Overview  
Schematics  
Recommended Configurations  
Tube Lists  
Assembly Instructions

05/29/2008

**GlassWare**  
AUDIO DESIGN

Copyright 2006-2008© All Rights Reserved

## 👉 **Warning!** 👈

This PCB is for use with a high-voltage power supply; thus, a real shock hazard exists. Once the power supply is attached, be cautious at all times. In fact, always assume that capacitors will have retained their charge even after the power supply is disconnected or shut down. If you are not an experienced electrical practitioner, before applying the B-plus voltage have someone who is experienced review your work. There are too few tube-loving solder slingers left; we cannot afford to lose any more.

## **Rev. C Overview**

Thank you for your purchase of the TCJ Aikido 9-pin stereo Rev. C PCB. This FR-4 PCB is extra thick, 0.094 inches (inserting and pulling tubes from their sockets won't bend or break this board), double-sided, with plated-through 2oz copper traces, and the boards are made in the USA. Each PCB holds two Aikido line-stage amplifiers; thus, one board is all that is needed for stereo unbalanced use or one board for one channel of balanced amplification. The boards are four inches by ten inches, with eight mounting holes, which help to prevent excessive PCB bending while inserting and pulling tubes from their sockets.

## **PCB Features**

**Redundant Solder Pads** This board holds two sets of differently-spaced solder pads for each critical resistor, so that radial and axial resistors can easily be used (bulk-foil resistors and carbon-film resistors, for example). In addition, most capacitor locations find many redundant solder pads, so wildly differing-sized coupling capacitors can be placed neatly on the board, without excessively bending their leads.

**Dual Coupling Capacitors** The boards hold two coupling capacitors, each finding its own 1M resistor to ground. Why? The idea here is that you can select (via a rotary switch) between C1 or C2 or both capacitors in parallel. Why again? One coupling capacitor can be Teflon and the other oil or polypropylene or bee's wax or wet-slug tantalum.... As they used to sing in a candy bar commercial: "Sometimes you feel like a nut; sometimes you don't."

Each type of capacitor has its virtues and failings. So use the one that best suits the music; for example, one type of coupling capacitors for old Frank Sinatra recordings and the other for Beethoven string quartets.

Or the same flavor capacitor can fill both spots: one lower-valued capacitor would set a low-frequency cutoff of 80Hz for background or late night listening; the other higher-valued capacitor, 5Hz for full range listening.

Or if you have found the perfect type of coupling capacitor, the two capacitors could be hardwired together on the PCBs via jumpers J8 and J9, one smaller one acting as a bypass capacitor for the larger coupling capacitor.

## Introduction to the Aikido

The Aikido amplifier delivers the sonic goods. It offers low distortion, low output impedance, a great PSRR figure, and feedback-free amplification. The secret to its superb performance— in spite not using global feedback— lies in its internal symmetry, which balances imperfections with imperfections. As a result, the Aikido circuit works at least a magnitude better than the equivalent SRPP or grounded-cathode amplifier.

For example, the Aikido circuit produces far less distortion than comparable circuits by using the triode's own nonlinearity against itself. The triode is not as linear as a resistor, so ideally, it should not see a linear load, but a corresponding, complementary, balancing non-linear load. An analogy is found in someone needing eyeglasses; if the eyes were perfect, then perfectly flat (perfectly linear) lenses would be needed, whereas imperfect eyes need counterbalancing lenses (non-linear lenses) to see straight. Now, loading a triode with the same triode— under the same cathode-to-plate voltage and idle current and with the same cathode resistor— works well to flatten the transfer curve out of the amplifier.

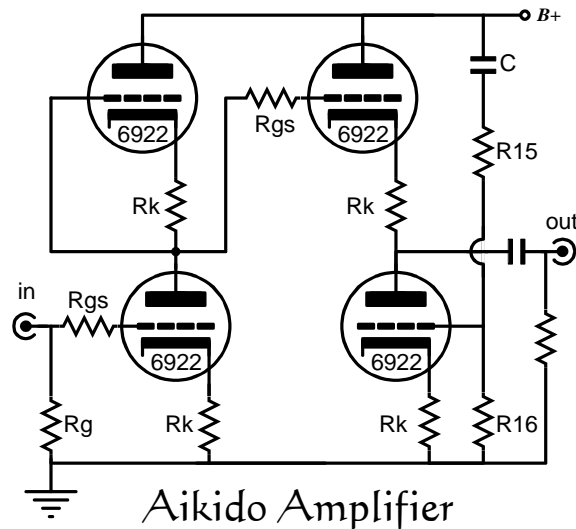

In the schematic above, the triodes are so specified for example only. Although they would never fit on the printed circuit board (PCBs), 211 and 845 triodes could be used to make an Aikido amplifier. The circuit does not rely on 6922 triodes or any other specific triodes to work correctly. It's the topology, not the tubes that make the Aikido special. (Far too many believe that a different triode equals a different topology; it doesn't. Making this mistake would be like thinking that the essential aspect of being a seeing-eye dog rested in being a Golden Lab.)

The Aikido circuit sidesteps power supply noise by incorporating the noise into its normal operation. The improved PSRR advantage is important, for it greatly unburdens the power-supply. With no tweaking or tube selecting, you should easily be able to get a -30dB PSRR figure (a conventional grounded-cathode amplifier with the same tubes and current draw yields only a -6dB PSRR); with some tweaking of resistor R15's value, -60dB or more is possible. Additionally, unless regulated power supplies are used for the plate and heater, these critical voltages will vary at the whim of the power company and your house's and neighbors' house's use, usually throwing the once fixed voltage relationships askew. Nevertheless, the Aikido amplifier will still function flawlessly, as it tracks these voltage changes symmetrically.

Remember, tubes are not yardsticks that never change, being more like car tires— they wear out. Just as a tire's weight and diameter decrease over time, so too the tube's conductance. So the fresh 6DJ8 is not the same as that same 6DJ8 after 2,000 hours of use. But as long as the two triodes age in the same way— which they are inclined to do, as they do the same amount of work and share the same materials and environment— the Aikido amplifier will always bias up correctly, splitting the B+ voltage between the triodes. Moreover, the Aikido amplifier does not make huge popping swings at start up, as the output does not start at the B+ and then swing down a hundred or so volts when the tube heats up, as it does in a ground-cathode amplifier.

This circuit eliminates power-supply noise from the output, by injecting the same amount of PS noise at the top and bottom of the two-tube cathode follower circuit. The way it works is that the input stage (the first two triodes) define a voltage divider of 50%, so that 50% of the PS noise is presented to the CF's grid; at the same time the 100k resistors also define a voltage divider of 50%, so the bottom triode's grid also sees 50% of the PS noise. Since both of these signals are equal in amplitude and phase, they cancel each other out, as each triodes sees an identical increase in plate current (imagine two equally strong men in a tug of war contest).

If the output connection is taken from the output cathode follower's cathode, then the balance will be broken. The same holds true if the cathode follower's cathode resistor is removed. (Besides, this resistor actually makes for a better sounding cathode follower, as it linearizes the cathode follower at the expense of a higher output impedance. Unfortunately, it should be removed and the bypass capacitor C3 should be used when driving low-impedance headphones, 32-ohms for example. When used as a line stage amplifier, no cathode resistor bypass capacitors should be used, as these capacitors are very much in the signal path and very few do not damage the sound, unless high quality capacitors are used.)

**How do I wire up a rotary switch for switching between the two coupling capacitors?** We need a four-pole, three-position switch and some hookup wire. All four coupling capacitors attach to the input contacts and the two channels of output can receive either coupling capacitors C1's or C2's or both capacitors' outputs. The drawing below shows the knob on the faceplate and the rotary switch from behind. (The switch is shown on the "C1 + C2" position.)

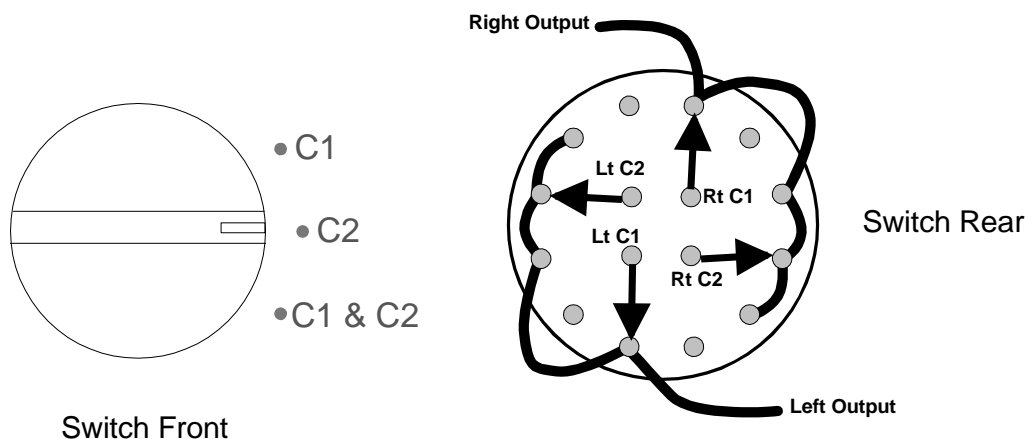

## Heater Issues

The board assumes that a DC 12V power supply will be used for the heaters, so that 6.3V heater tubes (like the 6FQ7 and 6DJ8) or 12.6V tubes (like the 12AU7 or 12AX7) can be used. Both types can be used exclusively, or simultaneously; for example 6GC7 for the input tube and a 12BH7 for the output tube. For example, if the input tube (V2 and V3) is a 12AX7 and the output tube is a 6H30 (V1 and V4), then use jumpers J1, J5 and J6.

**6V Heater Power Supply** Although designed for a 12V power supply, a 6V heater power supply can be used with the PCB, as long as all the tubes used have 6.3V heaters (or 5V or 8V or 18V power supply can be used, if all the tubes share the same 5V or 8V or 18V heater voltage). Just use jumpers J1 and J4 only. Note: Perfectly good tubes with uncommon heater voltages can often be found at swap meets, eBay, and surplus stores for a few dollars each. Think outside 6.3V box. (A 25V heater power supply can be used, if only 12.6V tubes are used. Just use the jumper settings that are listed on the PCB for 6V use. For example, if the input tube [V2 and V3] is a 12AX7 and the output tube is a 12AU7 [V1 and V4], then use jumpers J1 and J4.)

**AC Heaters** An AC heater power supply (6.3V or 12.6V) can be used, if the heater shunting capacitors C7, C8, C9, C10 are left off the board, or are replaced by 0.01 $\mu$ F ceramic capacitors.

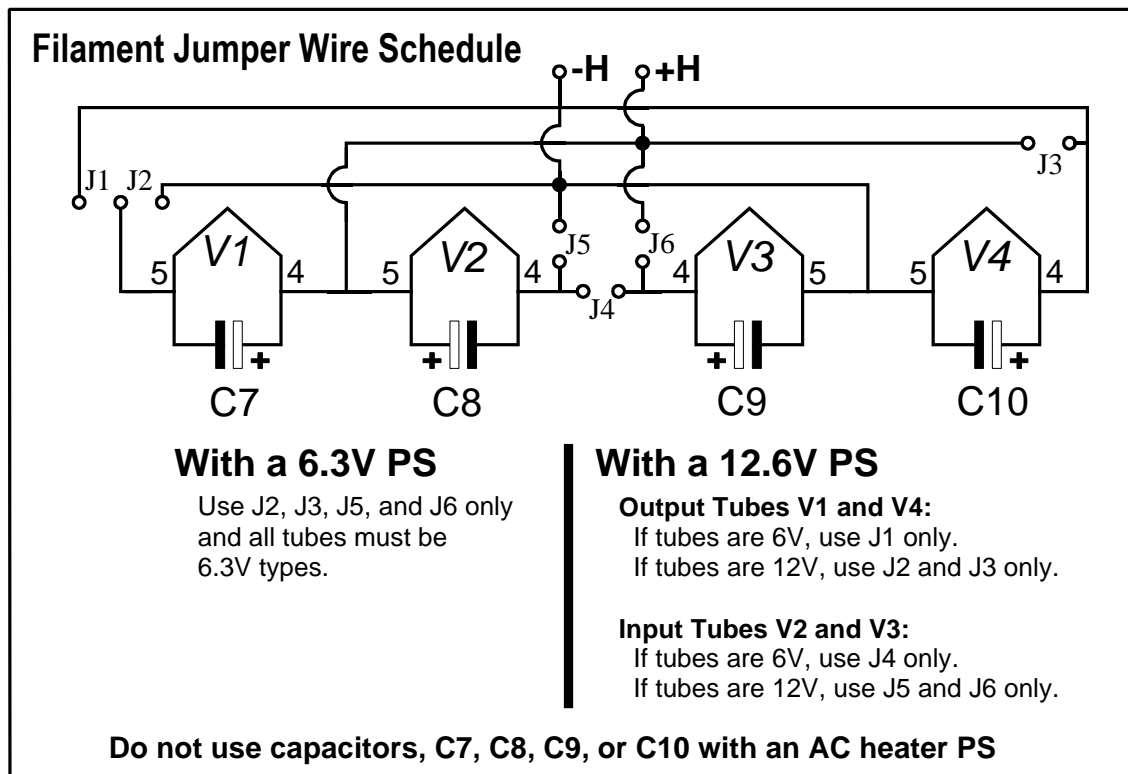

Since one triode stands atop another, the heater-to-cathode voltage experienced differs between triodes. The safest path is to reference the heater power supply to a voltage equal to one fourth the B+ voltage; for example, 75V, when using a 300V power supply. The  $\frac{1}{4}$  B+ voltage ensures that both top and bottom triodes see the same magnitude of heater-to-cathode voltage. The easiest way to set this voltage relationship up is the following circuit:

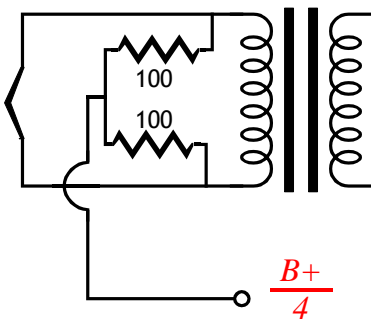
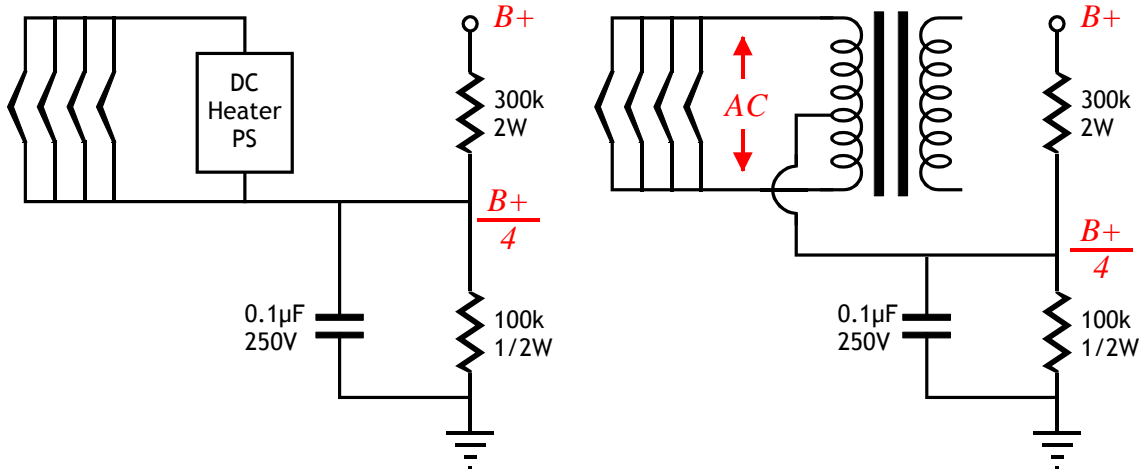

Alternatively, you might experiment with floating the heater power supply, by “grounding” the heater power supply via only a  $0.1\mu\text{F}$  film or ceramic capacitor. The capacitor will charge up through the leakage current between heater and cathodes. Not only is this method cheap, it is often quite effective in reducing hum.

### Power Supply

The power supply is external to the Aikido PCB and can be mounted in, or outside, the chassis that houses the PCB. The optimal power supply voltage depends on the tubes used. For example, 6GM8s (ECC86) can be used with a low 24V power supply, while 6FQ7s work better with a 250-300V B-plus voltage. The sky is not the limit here, as the heater-to-cathode voltage sets an upward limit of about 400V.

The genius of the Aikido circuit is found in both its low distortion and great PSRR figure. Nonetheless, a good power supply helps (there is a practical limit to how large a power-supply noise signal can be nulled). I recommend you use at least a solid, choke-filtered tube or fast-diode rectified power supply. If you insist on going the cheap route, try the circuit below, as it yields a lot of performance for little money. FRED rectifiers are expensive, but make an excellent upgrade to the lowly 1N4007.

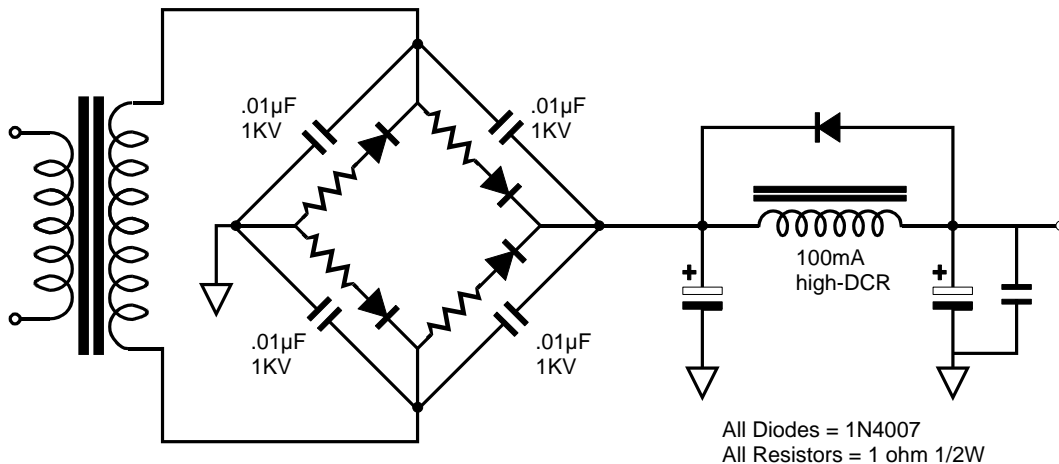

All Diodes = 1N4007  
All Resistors = 1 ohm 1/2W

Jumper J7 connects the PCB's ground to the chassis through the top centermost mounting hole. If you wish to float the chassis or capacitor couple the chassis to ground, then either leave jumper J7 out or replace it with a small-valued capacitor (0.01 to 0.1 $\mu$ F). Warning: if rubber O-rings are used with PCB standoffs, then the ground connection to the chassis is not likely to be made.

### Tube Selection

Unlike 99.9% of tube circuits, the Aikido amplifier defines a new topology without fixed part choices, not an old topology with specified part choices. In other words, an Aikido amplifier can be built in a nearly infinite number of ways. For example, a 12AX7 input tube will yield a gain close to 50 ( $\mu/2$ ), which would be suitable for a phono preamp or a SE amplifier's input stage; a 6FQ7 (6CG7) input tube will yield a gain near 10, which would be excellent for a line stage amplifier; the 6DJ8 or 6H30 in the output stage would deliver a low output impedance that could drive capacitance-laden cables or even high-impedance headphones. In other words, the list of possible tubes is a long one: 6AQ8, 6BC8, 6BK7, 6BQ7, 6BS8, 6DJ8, 6FQ7, 6GC7, 6H30, 6KN8, 6N1P, 12AT7, 12AU7, 12AV7, 12AX7, 12BH7, 12DJ8, 12FQ7, 5751, 5963, 5965, 6072, 6922, E188CC, ECC88, ECC99... The only stipulations are that the two triodes within the envelope be similar and that the tube conforms to the 9A or 9AJ base pin-out. Sadly, the 12B4 and 5687 cannot be used with this PCB.

### Internal Shields

If the triode's pin 9 attaches to an internal shield, as it does with the 6CG7 and 6DJ8, then capacitors, C11 and C12 can be replaced with a jumper, which will ground the shield. However, using the capacitors will also ground the shield (in AC terms) and allow using triodes whose pin-9 attaches to the center tap of its heater, such as the 12AU7.

### Cathode Resistor Values

The cathode resistor sets the idle current for the triode: the larger the value of the resistor, the less current. In general, high- $\mu$  triodes require high-value cathode resistors (1-2K) and low- $\mu$  triodes require low-valued cathode resistors (100-1k). I recommend running the output tubes hotter than the input tubes; or put differently, run the input tubes cooler than the output tubes. Interestingly enough, a lower idle current for the input stage does not seem to incur the same large increase in distortion that one would expect in other topologies (a testament to the Aikido's principle of symmetrical loading). For example, 1k cathode resistors for the input tube (V2 and V3) and 300-ohm resistors for the output tubes (V1 and V4), when using 6FQ7s or 6CG7s throughout. Thus, the output tubes will age more quickly than the input tubes, so rotating output for input tubes can extend the useful life of the tubes.

Capacitor C3 allows the bottom output triode's cathode resistor to be bypassed, when resistor R8 is replaced with a jumper wire; this arrangement is useful when driving low-impedance loads, such as 300-ohm or 32-ohm headphones, as it provides the lowest possible output impedance from the Aikido amplifier. If used, C3 should be at least a 1 $\mu$ F capacitor. On the other hand, if high-capacitance cable is to be driven, use a higher idle current and retain the cathode resistor, R8, and leave capacitor C3 off. Current is more important than the lowest possible output impedance.

## Configuring the PCB as a Line Amplifier

The Aikido topology makes a perfect line amplifier, as it offers low distortion, low output impedance, and excellent power-supply noise rejection— all without a global feedback loop. The key points are not to use capacitor C3. For guidance on part values, look at the page 12, which lists several line-amplifier design examples. Calculating R15's value is easy; it equals R16 against  $[(\mu - 2)/(\mu + 2)]$ . For example, a triode with a  $\mu$  of 20 results in  $R15 = 100k \times (20 - 2)/(20 + 2) = 81.8k$  (82k)

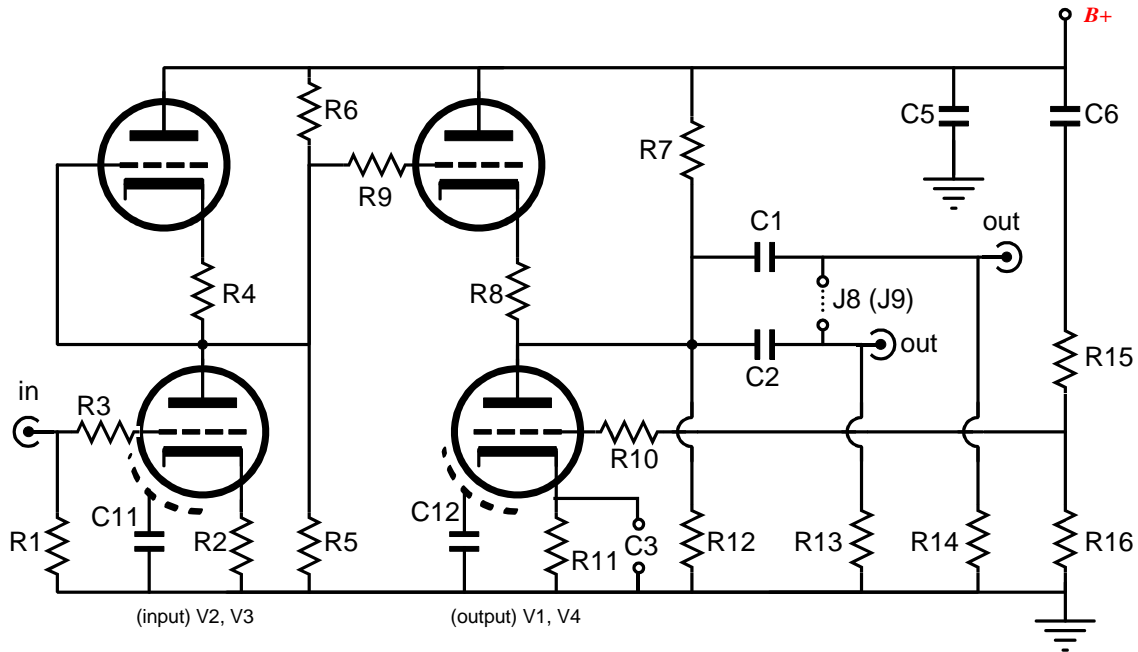

### Typical Part Values ( ) Parentheses denote recommended values

	6CG7 & 6DJ8	6CG7 & 6CG7	12AU7 & 12AU7	12AU7 & 12BH7
B+ Voltage =	170V - 250V (200V)	200V - 300V (300V)	200V - 300V (250V)	200V - 300V (300V)
Heater Voltage =	6.3V	6.3V	12.6V	12.6V
R1,5,6,7,12,13,14 =	1M	1M	1M	1M
R2,4 =	270 - 1k (470)*	470 - 2k (870)*	470 - 2k (680)*	470 - 2k (1k)*
R3,9,10 =	100 - 1k (300)*	Same	Same	Same
R8,11 =	200 - 330 (200 10mA)*	270 - 680 (270)*	180 - 470 (200)*	200 - 470 (523)*
R15 =	87.5k	83.2k	80k	79.3k
R16 =	100k	Same	Same	Same

\*High-quality resistors essential in this position  
All resistors 1/2W or higher

C1 =	0.1 - 4 $\mu$ F* Film	Same	Same	Same
C2 =	0.1 - 4 $\mu$ F* Oil	"	"	"
C3 =	none	"	"	"
C5 =	1 - 10 $\mu$ F* Film or Oil	"	"	"
C6 =	0.1 - 1 $\mu$ F* Film or Oil	"	"	"
C7,8,9,10 =	47 $\mu$ F - 1k $\mu$ F, 16V	"	"	"
C11,12 =	0.1 $\mu$ F 160V(optional)	Same	None	None

\*Voltage rating must equal or exceed B+ voltage

(input) V2, V3 =	6CG7, 6FQ7	6CG7, 6FQ7	12AU7, 5814, 5963, 6189, ECC82	12AU7, 5814, 5963, 6189, ECC82
(output) V1, V4 =	6DJ8, 6922, 7308, E88CC	6CG7, 6FQ7	12AU7, 5814, ECC82	12BH7, ECC99

## Configuring the PCB as a Headphone Amplifier

The standard Aikido is a thoroughly single-ended affair, nothing pulls while something else pushes. Unfortunately, wonderful as single-ended mode is sonically, it cannot provide the larger voltage and current swings that a push-pull output stage can. Single-ended stages can only deliver up to the idle current into a load, whereas class-A push-pull stages can deliver up to twice the idle current; and class-AB output stages can deliver many times the idle current. For a line stage, such big voltage and current swings are seldom required; headphones, on the other hand, do demand a lot more power; really, a 32-ohm load is brutally low impedance for any tube to drive. Unfortunately, a heavy idle current is needed to ensure large voltage swings into low-impedance loads.

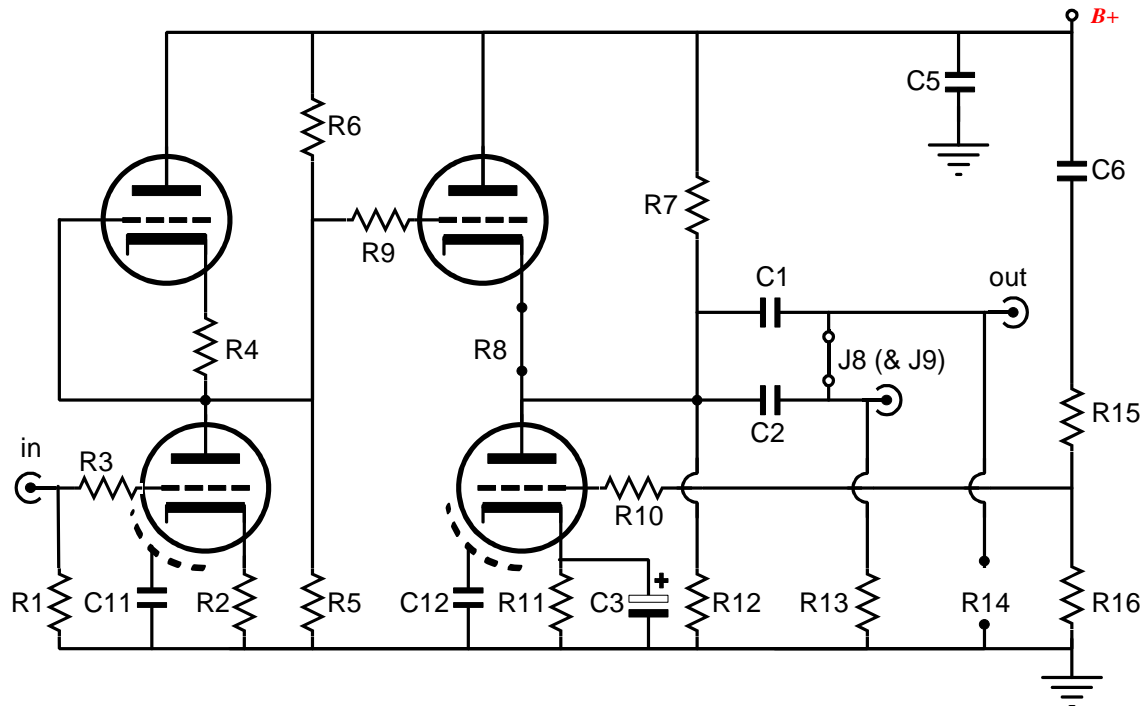

High transconductance output tubes are best for driving headphones, for example, the 6DJ8, 6H30, 12BH7, and ECC99. A coupling capacitor of at least  $33\mu\text{F}$  is required when driving 300-ohm headphones;  $330\mu\text{F}$  for 32-ohm headphones. Use a high-quality, small-valued bypass capacitor in C2's position. Capacitor C3 can be bypassed by placing a small film capacitor across the leads of resistor R11.

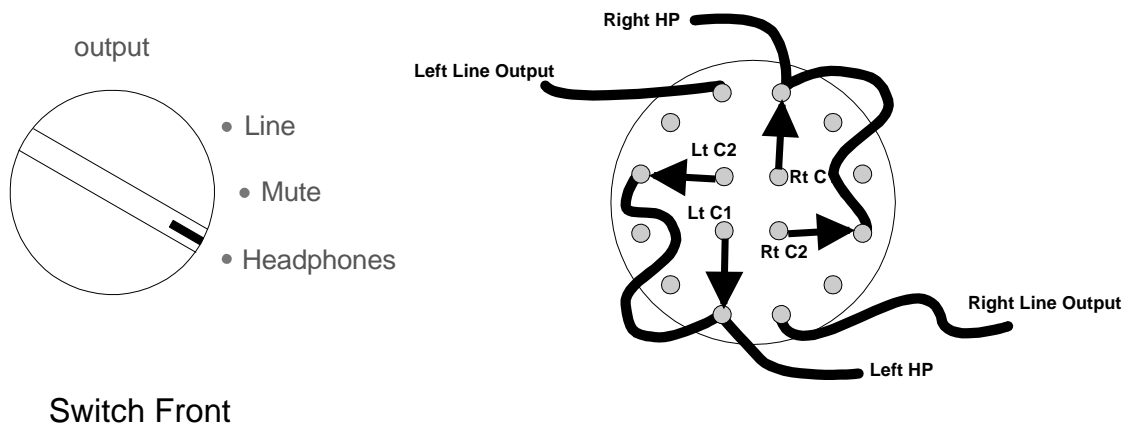

**Typical Part Values** ( ) Parentheses denote recommended values

	<b>6CG7 &amp; 6DJ8</b>	<b>6CG7 &amp; 6CG7</b>	<b>12AU7 &amp; 6H30</b>
B+ Voltage =	170V - 250V (250V)	200V - 300V (300V)	200V - 300V (150V)
Heater Voltage =	6.3V or 12.6V	6.3V or 12.6V	12.6V
R1,5,6,7,12,13 =	1M	1M	1M
R2,4 =	270 - 1k (640 5mA)*	470 - 2k (640 5mA)*	470 - 2k (741 3mA)*
R3,9,10 =	100 - 1k (300)*	100 - 1k (300)*	100 - 1k (300)*
R8,11 =	200 - 330 (291 10mA)*	200 - 470 (240 10mA)*	200 - 470 (74 30mA)*
R15 =	87.3k	83.2k	76.5k
R16 =	100k	100k	1 00k
*High-quality resistors essential in this position All resistors 1/2W or higher			
C1 =	47µF* Film for 300-ohm HP 470µF* for 32-ohm HP	Same Not recommended	Same 470µF* for 32-ohm HP
C2 =	0.47µF* Film or oil	Same	Same
C3 =	10 - 1kµF, 10V Electrolytic "10 - 1kµF, 16V Electrolytic	"	"
C5 =	1 - 10µF*	"	"
C6 =	0.047µF - 1µF* Film or oil	"	"
C7,8,9,10 =	10µF-1kµF, 16V Electrolytic	"	Same
C11,12 =	0.1µF 160V(optional)	"	None
*voltage rating must equal or exceed B+ voltage			
(input) V2, V3 =	6CG7, 6FQ7	6CG7, 6FQ7	12AU7, 5814, 5963, 6189, ECC82
(output) V1, V4 =	6DJ8, 6922, 7308, ECC88	6CG7, 6FQ7	6H30

**Assembly**

Before soldering, be sure to clean both sides of the PCB with 90% isopropyl alcohol, wiping away all fingerprints. First, solder the shortest parts (usually the resistors) in place, then the next tallest parts, and then the next tallest... Make sure that both the solder and the part leads are shiny and not dull gray. Steel wool can restore luster and sheen by rubbing off oxidation. If some of the parts have gold-plated leads, remove the gold flash before soldering the part, as only a few molecules of gold will poison a solder joint, making it brittle; use sandpaper, steel wool, or a solder pot. NASA forbids any gold-contaminated solder joints; you should as well. (Yes, there are many quality parts with gold-flashed leads, but the use of gold is a marketing gimmick.)

Normally, such as when the PCB sits on the floor of its chassis, all the parts sit on the top side of the PCB (the top side is marked). If you wish to have the tubes protrude from holes on the top of the chassis (and to place the PCB within 1" of the top panel with the aid of standoffs), then all the other parts— *except* the tube sockets— can be placed on the PCB's backside; it is a double-sided board after all (be sure to observe the electrolytic capacitors' polarity and glue or tie-wrap heavy coupling capacitors to the PCB).

**Let me know what you think**

If you would like to see some new audio PCB or kit or recommend a change to an existing product or if you need help figuring out the heater jumper settings or cathode resistor values, drop me a line by e-mail to the address above (begin the subject line with either "Aikido" or "tube").

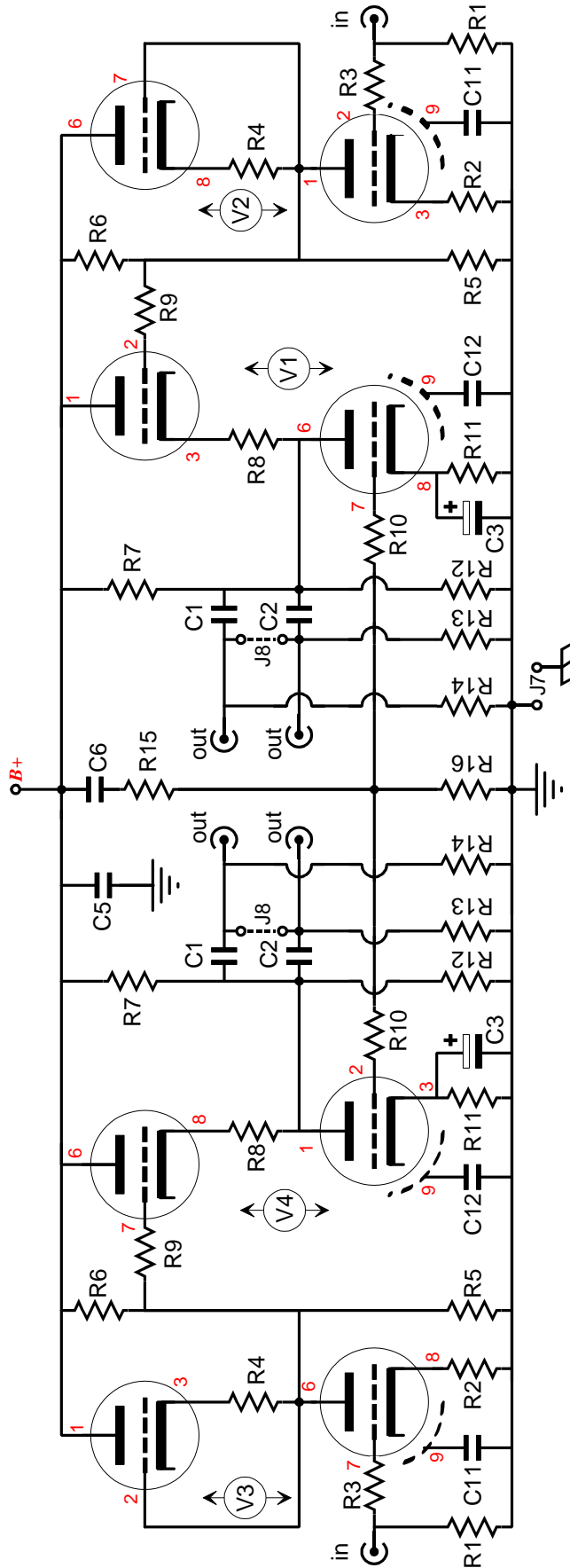

**9-Pin Aikido Schematic (Rev. C)**

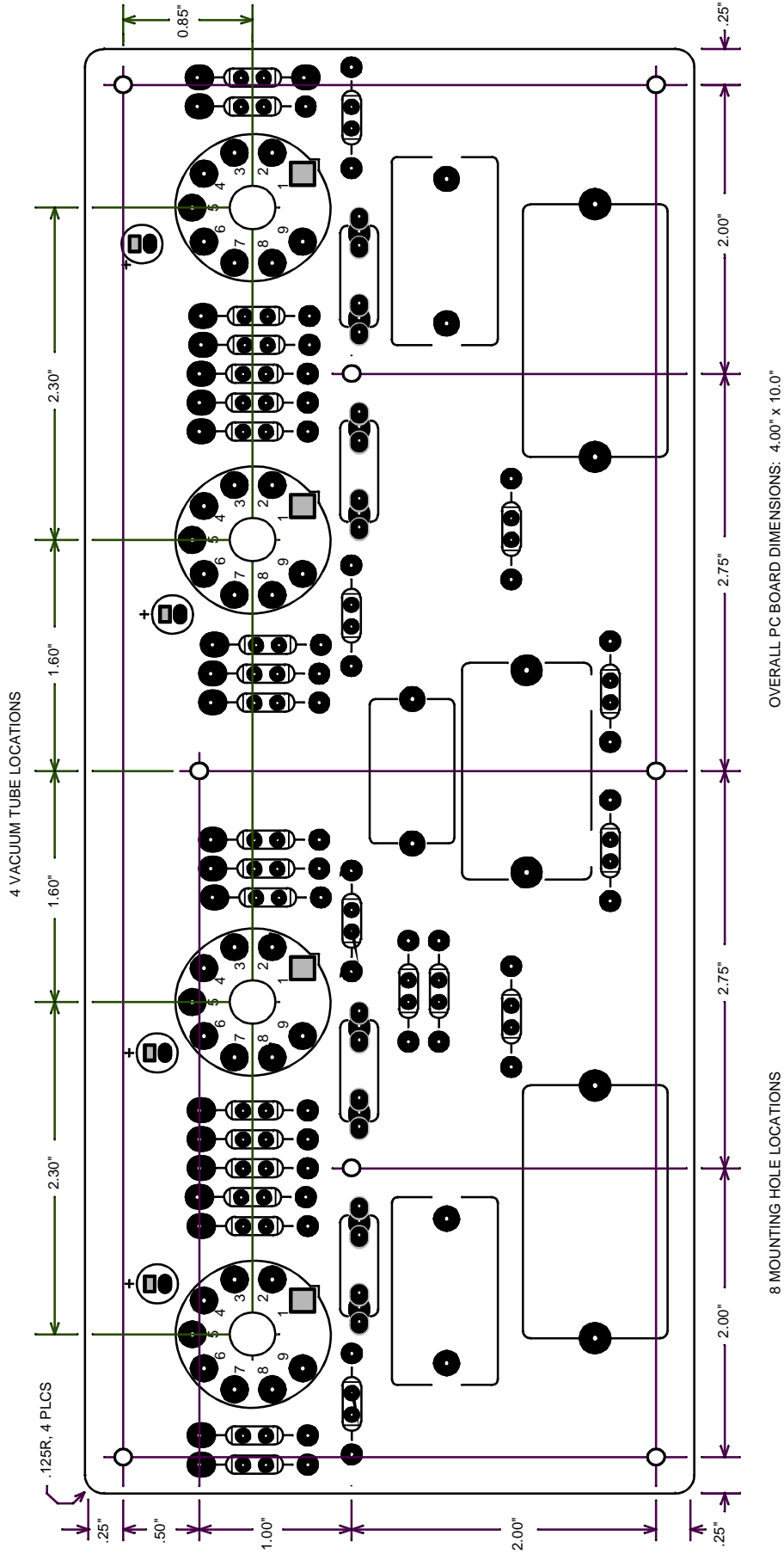

Top Side PCB Mechanical Layout

Tube	B+	Ik(mA)	mu	rp	Rk	R15	R16	R17	Input Gain	Input Gain dBs	Output Gain	Output in dBs	Zo Line Amp.	Zo HP Amp
6AQ8	300V	10.0	57.0	9700	100	93.2k	100k	170	28.1	29.0	0.97	-0.24	248	85
6BK7	300V	10.0	43.0	4600	200	91.1k	100k	107	21.2	26.5	0.97	-0.27	279	53
6BQ7	300V	10.0	38.0	5900	191	90.0k	100k	155	18.7	25.5	0.96	-0.32	311	78
6BS8	300V	10.0	36.0	5000	220	89.5k	100k	139	17.8	25.0	0.96	-0.33	321	69
6CG7	150V	3.0	20.5	10200	583	82.2k	100k	498	10.0	20.0	0.93	-0.59	827	249
6CG7	200V	5.0	21.1	8960	397	82.7k	100k	425	10.4	20.3	0.93	-0.59	657	212
6CG7	250V	5.0	21.0	9250	626	82.6k	100k	440	10.3	20.2	0.94	-0.56	820	220
6CG7	300V	4.5	20.8	9840	1000	82.5k	100k	473	10.1	20.1	0.94	-0.53	1063	237
6CG7	300V	7.3	21.4	8370	470	82.9k	100k	391	10.5	20.4	0.94	-0.56	686	196
6CG7	300V	10.0	21.9	7530	243	83.3k	100k	344	10.8	20.7	0.93	-0.60	489	172
6CG7	350V	10.0	21.8	7680	352	83.2k	100k	352	10.7	20.6	0.94	-0.57	576	176
6DJ8	100V	5.0	30.2	3670	182	87.6k	100k	122	15.0	23.5	0.96	-0.39	273	61
6DJ8	150V	10.0	30.7	2870	124	87.8k	100k	93	15.2	23.7	0.96	-0.39	199	47
6DJ8	200V	10.0	30.0	2960	205	87.5k	100k	99	14.9	23.4	0.96	-0.37	274	49
6DJ8	250V	10.0	29.6	3060	291	87.3k	100k	103	14.6	23.3	0.96	-0.36	350	52
6DJ8	250V	5.0	28.6	3980	673	86.9k	100k	139	14.0	22.9	0.96	-0.35	667	70
6DJ8	300V	5.0	28.3	4080	845	86.8k	100k	144	13.8	22.8	0.96	-0.34	787	72
6DJ8	300V	8.0	28.9	3400	481	87.1k	100k	118	14.2	23.0	0.96	-0.35	511	59
6FQ7	See 6CG7 and 6SN7													
6GM8	24V	2.0	14.0	3400	187	75.0k	100k	243	7.0	16.8	0.90	-0.90	357	121
6H30	100V	20.0	15.4	1140	69	77.0k	100k	74	7.7	17.7	0.91	-0.80	127	37
6H30	150V	30.0	15.9	1040	74	77.7k	100k	65	7.9	18.0	0.92	-0.75	124	33
6H30	200V	20.0	15.4	1310	221	77.0k	100k	85	7.7	17.7	0.92	-0.68	267	43
6H30	250V	20.0	15.4	1380	294	77.0k	100k	90	7.7	17.7	0.93	-0.66	330	45
6H30	300V	15.0	15.0	1670	530	76.5k	100k	111	7.4	17.4	0.93	-0.65	528	56
6N1P	200V	3.0	39.8	12200	328	90.4k	100k	307	19.4	25.8	0.96	-0.32	539	153
6N1P	250V	5.0	36.0	9480	221	89.5k	100k	263	17.7	25.0	0.96	-0.36	422	132
6N1P	300V	5.0	35.0	956	642	89.2k	100k	27	17.1	24.7	0.97	-0.25	569	14
6N27P	24V	2.0	14.0	3400	187	75.0k	100k	243	7.0	16.8	0.90	-0.90	357	121
9AQ8	See 6AQ8													
12AT7	200V	3.7	60.0	15000	270	93.5k	100k	250	29.1	29.3	0.98	-0.21	457	125
12AU7	100V	2.5	17.0	9560	427	78.9k	100k	562	8.4	18.4	0.92	-0.75	757	281
12AU7	150V	3.0	16.6	9570	741	78.5k	100k	577	8.1	18.2	0.92	-0.71	959	288
12AU7	200V	4.0	16.7	9130	768	78.6k	100k	547	8.2	18.2	0.92	-0.69	959	273
12AU7	250V	8.0	17.9	7440	336	79.9k	100k	416	8.8	18.9	0.92	-0.71	601	208
12AU7	300V	10.0	18.1	7120	328	80.1k	100k	393	8.9	19.0	0.92	-0.70	581	197
12AV7	200V	9.0	37.0	6100	120	89.7k	100k	165	18.3	25.3	0.96	-0.36	258	82
12AV7	300V	18.0	41.0	4800	56	90.7k		117	20.4	26.2	0.96	-0.35	160	59
12AZ7	See 12AT7													
12AX7	200V	0.5	100.0	80000	2000	96.1k	100k	800	39.0	31.8	0.99	-0.11	1719	400
12AX7	300V	1.0	100.0	62500	1100	96.1k	100k	625	42.6	32.6	0.99	-0.12	1238	313
12BH7	100V	4.0	16.1	5480	340	77.9k	100k	340	8.0	18.0	0.92	-0.76	549	170
12BH7	150V	4.0	15.7	6090	706	77.4k	100k	388	7.7	17.7	0.92	-0.71	826	194
12BH7	200V	5.0	15.9	6140	787	77.7k	100k	386	7.8	17.8	0.92	-0.68	877	193
12BH7	250V	10.0	17.4	4870	383	79.4k	100k	280	8.6	18.7	0.93	-0.67	541	140
12BH7	300V	15.0	18.4	4300	267	80.4k	100k	234	9.1	19.2	0.93	-0.65	422	117
12BZ7	300V		100.0	31800		96.1k	100k	318	48.5	33.7	0.98	-0.17	292	159
12DJ8	See 6DJ8													
12FQ7	See 6SN7													
5687	150V	24.0	18.1	1760	37	80.1k	100k	97	9.0	19.1	0.91	-0.78	119	49
5687	200V	20.0	17.5	1970	132	79.5k	100k	113	8.7	18.8	0.92	-0.68	216	56
5687	250V	20.0	17.4	2060	198	79.4k	100k	118	8.7	18.7	0.93	-0.65	276	59
5687	300V	15.0	16.9	2440	397	78.8k	100k	144	8.4	18.5	0.93	-0.62	455	72
5751	200V	0.8	70.0	58000	1250	94.4k	100k	829	30.5	29.7	0.98	-0.17	1407	414
5963	250V	10.0	21.0	6600	200	82.6k	100k	314	10.4	20.3	0.93	-0.63	433	157
5965	300V	8.2	47.0	7250	220	91.8k	100k	154	23.1	27.3	0.97	-0.26	337	77
6072	300V	2.0	44.0	25000	1250	91.3k	100k	568	20.3	26.2	0.97	-0.25	1272	284
7119	300V	15.0	21.7	2390	324	83.1k	100k	110	10.7	20.6	0.95	-0.48	377	55
ECC81	See 12AT7													
ECC82	See 12AU7													
ECC83	See 12AX7													
ECC85	See 6AQ8													
ECC86	See 6GM8													

The table above lists many triodes suitable for the 9-pin-based Aikido amplifier PCB. The table lists the same tube under different B+ voltages and with different cathode resistor values. Two gains are listed: the first is the gain the tube realizes in the input position in the Aikido; the second is the gain of the same tube in the output stage. To calculate the final gain multiply the two voltage gains together (or add the gain in dBs together). For example, given an Aikido line amplifier with a B+ voltage of 300V, and a 6CG7 input tube with cathode resistors of 1k, and a 6DJ8 output tube with cathode resistors of 481 ohms, the final voltage gain equals 10.1 from the 6CG7 against the 0.96 gain of the 6DJ8, with a product of 9.7. or, working with dB instead, 20.1dB plus -35dB, for a total of 19.75dB. (Aren't decibels great?)